

NATIONAL BUILDING CODE OF INDIA

PART 4 FIRE AND LIFE SAFETY

BUREAU OF INDIAN STANDARDS

CONTENTS

FOREWORD	...	3
1 SCOPE	...	7
2 TERMINOLOGY	...	7
3 FIRE PREVENTION	...	9
4 LIFE SAFETY	...	26
5 FIRE PROTECTION	...	32
6 ADDITIONAL OCCUPANCY-WISE REQUIREMENTS	...	49
ANNEX A CALORIFIC VALUES OF COMMON MATERIALS AND TYPICAL VALUES OF FIRE LOAD DENSITY	...	62
ANNEX B BROAD CLASSIFICATION OF INDUSTRIAL AND NON-INDUSTRIAL OCCUPANCIES INTO DIFFERENT DEGREE OF HAZARD	...	63
ANNEX C FIRE PROTECTION REQUIREMENTS FOR HIGH RISE BUILDINGS — 15 m IN HEIGHT OR ABOVE	...	65
ANNEX D FIRE PROTECTION CONSIDERATIONS FOR VENTING IN INDUSTRIAL BUILDINGS	...	71
ANNEX E GUIDELINES FOR FIRE DRILL AND EVACUATION PROCEDURES FOR HIGH RISE BUILDINGS (ABOVE 15 m IN HEIGHT)	...	77
LIST OF STANDARDS	...	83

FOREWORD

This Part of the Code deals with safety from fire. It specifies the demarcation of fire zones, restrictions on construction of buildings in each fire zone, classification of buildings based on occupancy, types of building construction according to fire resistance of the structural and non-structural components and other restrictions and requirements necessary to minimize danger to life from fire, smoke, fumes or panic before the buildings can be evacuated. The Code recognizes that safety of life is more than a matter of means of exits and accordingly deals with various matters which are considered essential to the safety of life.

Fire protection techniques have to be based on the fire behaviour characteristics of different materials and structural elements of buildings. The activities pursued by the occupants of buildings must also be taken into consideration for assessing the extent of hazards, and method should then be devised by which the hazards could be minimized. An indefinite combination of variables is involved in the phenomenon of fire, all of which cannot be quantified. The requirements of this Code should, therefore, be taken as a guide and an engineering design approach should be adopted for ensuring a fire safe design for buildings. It would also be necessary for this purpose to associate qualified and trained fire protection engineers with the planning of buildings, so that adequate fire protection measures could be incorporated in the building design right from the beginning.

Absolute safety from fire is not attainable in practice. The objective of this Part is to specify measures that will provide that degree of safety from fire which can be reasonably achieved. The Code endeavours to avoid requirements that might involve unreasonable hardships or unnecessary inconvenience or interference with normal use and occupancy of buildings, but insists upon compliance with minimum standards for fire safety necessary in public interest. For ensuring compliance of fire protection equipments/installations to the laid down quality requirements, it is desirable to use such equipments/installation duly certified under the BIS Certification Marks Scheme.

While providing guidelines for minimizing chances of occurrence of fire through passive fire protection measures, this Part does not intend to cover all aspects of general fire prevention including sources of ignition. Nor does it cover the prevention of accidental personal injuries during the course of normal occupancy of buildings.

This Part while recognizing that panic in a building on fire may be uncontrollable, deals with the potential panic hazard through measures designed to prevent the development of panic. Experience indicates that panic seldom develops even in the presence of potential danger, so long as occupants of buildings are moving towards exits which they can see within a reasonable distance and with no obstruction or undue congestion in the path of travel. However, any uncertainty as to the location or adequacy of means of egress, the presence of smoke or fumes and the stoppage of travel towards the exit, such as may occur when one person stumbles and falls on stairs, may be conducive to panic. Danger from panic is greater when a large number of people are trapped in a confined area.

Experience has shown that concealed spaces within a building, such as, space between ceiling and false ceiling, horizontal and vertical ducts, etc, tend to act as flues/tunnels during a fire. Provision should, therefore, be made to provide fire stopping within such spaces.

Nothing in this Part of the Code shall be construed to prohibit better types of building construction, more exits or otherwise safer conditions than the minimum requirements specified in this Part.

Compliance with this Part shall not be construed as eliminating or reducing the necessity for other provisions for safety of persons using a building or structure under normal occupancy conditions. Nor shall any provision of this Code be construed as requiring or permitting any addition that may be hazardous under normal occupancy conditions.

One of the major points brought out in this Part is the limitation of heights and areas of buildings based on fire safety of the occupants. Individual municipal corporations are free to alter Table 19 based on local conditions,

but the ratios of areas as maintained in the table for different occupancies and types of construction shall be adhered to.

Advantage has been taken of the developments, particularly in fire resistance rating of materials, designating types of construction in a rational manner and relating the area limitations of different occupancies to different types of construction.

Halons (halogenated hydrocarbons) which exhibit exceptional fire fighting and explosion prevention/suppression characteristics have been found to possess high ozone depleting potential. They come under Group II of Annex A of the Montreal Protocol on Substances that Deplete the Ozone Layer, the international environmental agreement for phasing out ozone depleting substances. Due to increasing evidence that the ozone layer is getting depleted at a faster rate than thought earlier, the developed countries accelerated their phase-out schedule with a view to achieving 100 percent phase-out of halons by 1 January 1994, instead of the earlier target date of 1 January 2000 after which only essential use of halon was allowed. For developing countries like India, the total phase-out of halons is to be achieved by 1 January 2010, as per Montreal Protocol, unless a decision is taken in between to hasten up the phase-out of ozone depleting substances. India, having become a signatory to the Protocol in June 1992, is committed to abide by the Montreal Protocol decisions. In accordance with Ministry of Environment and Forests, Government of India, Ozone Depleting Substances (Regulations), Rules, 2000, the manufacture of halon based fire extinguishers and extinguishing systems has been phased out by 1 January 2001. Meanwhile, the practical implications of the phasing out of the halons cover, by and large, the following aspects:

- a) Availability of halons will be restricted;
- b) Non-standard halon extinguishers, like aerosol type, shall not be permitted;
- c) Discharge of halons for training/testing, etc shall not be permitted;
- d) All efforts shall be made for avoiding/minimizing halon emissions at various levels such as production, fire equipment manufacture, use, service and maintenance;
- e) Since 'drop-in' substitutes for halons are not likely to be available on a commercial scale in the near future, wherever possible, instead of halon, use of suitable alternative extinguishing media/methods will be resorted to, even accepting some trade-offs, if necessary; and
- f) Halons shall be restricted for 'essential uses' only, for protection of critical fire explosion risk areas which would otherwise result in serious impairment of an essential service to society, or pose an unacceptable threat to life, the environment, or national security.

NOTE — Detailed instructions which will be issued by the Government of India from time-to-time for implementation of the Country Programme for the phasing out of ozone depleting substance (ODS) and regarding permitting use of halons for applications till the availability of proper substitutes, shall have to be complied with.

The first version of this Part was formulated in 1970 and first revision was brought out in 1983. Subsequently the first revision of this Part was modified in 1997 through Amendment No. 3 to 1983 version of the Code. This modified version of this part included few tables for the fire resistance ratings of various building components, such as walls, columns, beams and floors. The requirements for wet riser, down-comer, automatic sprinkler installation, high velocity (10-15 m/s) water spray or foam generating system, etc, for buildings were modified. Annex giving guidelines for selection of fire detectors had been deleted and relevant Indian Standards on fire alarm system and smoke detectors had been referred. Also, Annex for determination of fire loads and fire load density for arriving at the classification of occupancy hazard and calorific values of some common materials were included. Annex for broad classification of industrial and non-industrial occupancies into low, moderate and high hazard had also been included.

As a result of implementation of this Part, some useful suggestions have emerged. This revision has, therefore, been prepared to take care of the same. The significant modifications incorporated include:

- a) The text has now been divided into the following broad clauses:
 - 1) *Fire Prevention* — Covering aspects of fire prevention pertaining to design and construction of buildings on passive fire protection measures, also describing the various types of building materials and their fire rating.
 - 2) *Life Safety* — Covering life safety provisions in the event of fire and similar emergencies, also addressing construction and occupancy features that are necessary to minimize danger to life from fire, smoke, fumes or panic.

- 3) *Fire Protection* — covering the significant appurtenances and their related components and guidelines for selecting the correct type of equipment and installation meant for fire protection of the building, depending upon the classification and type of the building.
- b) The classification of building based on occupancy has been elaborated, with:
 - 1) Starred hotels now covered as a new sub-division A-6 under occupancy Group A Residential.
 - 2) Heritage structures and archeological monuments now covered under sub-division D-3 occupancy Group D Assembly buildings.
 - 3) Mixed assembly occupancies now covered as a new sub-division D-6 and under ground elevated railways have been covered as a new sub-division D-7 under occupancy Group D Assembly buildings.
 - 4) TV stations now covered under sub-division E-5 of occupancy Group E Business buildings.
- c) The minimum capacity of smoke exhaust equipment has been increased to 12 air changes per hour.
- d) For the external stairs for exit requirements, the width and treads have been increased to 1 250 mm and 250 mm respectively.
- e) Under the requirements for institutional buildings the clear width of all required exits which serve as egress from hospital or infirmary section has been increased from 1.5 m to 2 m. Also, provision of patient-lift has been included.
- f) Due cognizance of halon phase out programme has been taken, while specifying provisions in this Part with respect to fire protection using fire extinguishers/systems.

All standards cross-referred to in the main text of this section, are subject to the revision. The parties to agreement based on this Part are encouraged to investigate the possibility of applying the most recent editions of the standards.



NATIONAL BUILDING CODE OF INDIA

PART 4 FIRE AND LIFE SAFETY

1 SCOPE

This Part covers the requirements for fire prevention, life safety in relation to fire and fire protection of buildings. The Code specifies construction, occupancy and protection features that are necessary to minimize danger to life and property from fire.

2 TERMINOLOGY

2.0 For the purpose of this Part, the following definitions shall apply.

2.1 Automatic Fire Detection and Alarm System — Fire alarm system comprising components for automatically detecting a fire, initiating an alarm of fire and initiating other actions as appropriate.

NOTE — The system may also include manual fire alarm call points.

2.2 Automatic Sprinkler System — A system of water pipes fitted with sprinkler heads at suitable intervals and heights and designed to actuate automatically, control and extinguish a fire by the discharge of water.

2.3 Building — Any structure for whatsoever purpose and of whatsoever materials constructed and every part thereof whether used as human habitation or not and includes foundation, plinth, walls, floors, roofs, chimneys, plumbing and building services, fixed platforms, VERANDA, balcony, cornice or projection, part of a building or anything affixed thereto or any wall enclosing or intended to enclose any land or space and signs and outdoor display structures. Tents, SHAMIANAHS, tarpaulin shelters, etc, erected for temporary and ceremonial occasions with the permission of the Authority shall not be considered as building.

2.4 Building, Height of — The vertical distance measured in the case of flat roofs, from the average level of the ground around and contiguous to the building or as decided by the Authority to the terrace of the last livable floor of the building adjacent to the external wall; and in the case of pitched roofs, up to the point where the external surface of the outer wall intersects the finished surface of the sloping roof; and in the case of gables facing the road, the mid-point between the eaves level and the ridge. Architectural features serving no other function except that of decoration, shall be excluded for the purpose of measuring heights.

2.5 Combustible Material — The material which either burns itself or adds heat to a fire, when tested for non-combustibility in accordance with accepted standard [4(1)].

2.6 Covered Area — Ground area covered by the

building immediately above the plinth level. The area covered by the following in the open spaces is excluded from covered area (see Table 19):

- a) garden, rockery, well and well structures, plant nursery, waterpool, swimming pool (if uncovered), platform round a tree, tank, fountain, bench, CHABUTARA with open top and unenclosed on sides by walls and the like;
- b) drainage culvert, conduit, catch-pit, gully pit, chamber, gutter and the like;
- c) compound wall, gate, unstoreyed porch and portico, slide, swing, uncovered staircases, ramp areas covered by CHHAJJA and the like; and
- d) watchman's booth, pumphouse, garbage shaft, electric cabin or sub-stations, and such other utility structures meant for the services of the building under consideration.

NOTE — For the purpose of this Part, covered area equals the plot area minus the area due for open spaces in the plot.

2.7 Down-comer — An arrangement of fire fighting within the building by means of down-comer pipe connected to terrace tank through terrace pump, gate valve and non-return valve and having mains not less than 100 mm internal diameter with landing valves on each floor/landing. It is also fitted with inlet connections at ground level for charging with water by pumping from fire service appliances and air release valve at roof level to release trapped air inside.

2.8 Dry Riser — An arrangement of fire fighting within the building by means of vertical rising mains not less than 100 mm internal diameter with landing valves on each floor/landing which is normally dry but is capable of being charged with water usually by pumping from fire service appliances.

2.9 Emergency Lighting — Lighting provided for use when the supply to the normal lighting fails.

2.10 Emergency Lighting System — A complete but discrete emergency lighting installation from the standby power source to the emergency lighting lamp(s), for example, self-contained emergency luminaire or a circuit from central battery generator connected through wiring to several escape luminaries.

2.11 Escape Lighting — That part of emergency lighting which is provided to ensure that the escape route is illuminated at all material times, for example, at all times when persons are on the premises, or at times the main lighting is not available, either for the whole building or for the escape routes.

2.12 Fire Door — A fire-resistive door approved for openings in fire separation.

2.13 Fire Exit — A way out leading to an escape route having panic bar hardware provided on the door.

2.14 Fire Lift — The lift installed to enable fire services personnel to reach different floors with minimum delay, having such features as required in accordance with this Part.

2.15 Fire Load — Calorific energy, of the whole contents contained in a space, including the facings of the walls, partitions, floors and ceilings.

2.16 Fire Load Density — Fire load divided by floor area.

2.17 Fire Resistance Rating — The time that a material or construction will withstand the standard fire exposure as determined by fire test done in accordance with the standard methods of fire tests of materials/structures.

2.18 Fire Resistance — Fire resistance is a property of an element of building construction and is the measure of its ability to satisfy for a stated period some or all of the following criteria:

- a) resistance to collapse,
- b) resistance to penetration of flame and hot gases, and
- c) resistance to temperature rise on the unexposed face up to a maximum of 180°C and/or average temperature of 150°C.

2.19 Fire Separation — The distance in metres measured from the external wall of the building concerned to the external wall of any other building on the site, or from other site, or from the opposite side of street or other public space for the purpose of preventing the spread of fire.

2.20 Fire Separating Wall — The wall provides complete separation of one building from another or part of a building from another or part of a building from another part of the same building to prevent any communication of fire or heat transmission to wall itself which may cause or assist in the combustion of materials on the side opposite to that portion which may be on fire.

2.21 Fire Stop — A fire resistant material, or construction, having a fire resistance rating of not less than the fire separating elements, installed in concealed spaces or between structural elements of a building to prevent the spread/propagation of fire and smoke through walls, ceilings and like as per the laid down criteria.

2.22 Fire Tower — An enclosed staircase which can only be approached from the various floors through landings or lobbies separated from both the floor areas

and the staircase by fire-resisting doors, and open to the outer air.

2.23 Fire Resisting Wall — A fire resistance rated wall, having protected openings, which restricts the spread of fire and extends continuously from the foundation to at least 1 m above the roof.

2.24 Floor Area Ratio (FAR) — The quotient obtained by dividing the total covered area (plinth area) on all floors by the area of the plot:

$$\text{FAR} = \frac{\text{Total covered area of all floors}}{\text{Plot area}}$$

2.25 High Rise Building — For the purpose of this Part, all buildings 15 m or above in height shall be considered as high rise buildings.

2.26 Horizontal Exit — An arrangement which allows alternative egress from a floor area to another floor at or near the same level in an adjoining building or an adjoining part of the same building with adequate fire separation.

2.27 Means of Egress — A continuous and unobstructed way of travel from any point in a building or structure to a place of comparative safety.

2.28 Occupancy or Use Group — The principal occupancy for which a building or a part of a building is used or intended to be used, for the purpose of classification of a building according to the occupancy, an occupancy shall be deemed to include subsidiary occupancies which are contingent upon it.

2.29 Plinth Area — The built-up covered area measured at the floor level of the basement or of any storey.

2.30 Pressurization — The establishment of a pressure difference across a barrier to protect a stairway, lobby, escape route or room of a building from smoke penetration.

2.31 Pressurization Level — The pressure difference between the pressurized space and the area served by the pressurized escape route, expressed in pascals (Pa).

2.32 Roof Exits — A means of escape on to the roof of a building, where the roof has access to it from the ground. The exit shall have adequate cut-off within the building from staircase below.

2.33 Site Plot — A parcel (piece) of land enclosed by definite boundaries.

2.34 Stack Pressure — Pressure difference caused by a temperature difference creating an air movement within a duct, chimney or enclosure.

2.35 Travel Distance — The distance to be travelled from any point in a building to a protected escape route, external escape route or final exit.

2.36 Ventilation — Supply of outside air into, or the removal of inside air from an enclosed space.

2.37 Venting Fire — The process of inducing heat and smoke to leave a building as quickly as possible by such paths that lateral spread of fire and heat is checked, fire fighting operations are facilitated and minimum fire damage is caused.

2.38 Volume to Plot Area Ratio (VPR) — The ratio of volume of building measured in cubic metres to the area of the plot measured in square metres and expressed in metres.

2.39 Wet Riser — An arrangement for fire fighting within the building by means of vertical rising mains not less than 100 mm nominal diameter with landing valves on each floor/landing for fire fighting purposes and permanently charged with water from a pressurized supply.

NOTE — For definitions of other terms, reference shall be made to good practice [4(2)].

3 FIRE PREVENTION

3.1 Classification of Building Based on Occupancy

3.1.1 General Classification

All buildings, whether existing or hereafter erected shall be classified according to the use or the character of occupancy in one of the following groups:

Group A	Residential
Group B	Educational
Group C	Institutional
Group D	Assembly
Group E	Business
Group F	Mercantile
Group G	Industrial
Group H	Storage
Group J	Hazardous

3.1.1.1 Minor occupancy incidental to operations in another type of occupancy shall be considered as part of the main occupancy and shall be classified under the relevant group for the main occupancy.

Examples of buildings in each group are given in 3.1.2 to 3.1.10.

3.1.2 Group A Residential Buildings

These shall include any building in which sleeping accommodation is provided for normal residential purposes with or without cooking or dining or both facilities, except any building classified under Group C.

Buildings and structures under Group A shall be further sub-divided as follows:

Sub-division A-1 Lodging or rooming houses

Sub-division A-2 One or two-family private dwellings

Sub-division A-3 Dormitories

Sub-division A-4 Apartment houses (flats)

Sub-division A-5 Hotels

Sub-division A-6 Hotels (Starred)

a) *Sub-division A-1 Lodging or rooming houses* — These shall include any building or group of buildings under the same management, in which separate sleeping accommodation for a total of not more than 40 persons (beds), on transient or permanent basis, with or without dining facilities but without cooking facilities for individuals is provided. This includes inns, clubs, motels and guest houses.

A lodging or rooming house shall be classified as a dwelling in sub-division A-2 if no room in any of its private dwelling units is rented to more than three persons.

b) *Sub-division A-2 One or two-family private dwellings* — These shall include any private dwelling which is occupied by members of one or two families and has a total sleeping accommodation for not more than 20 persons. If rooms in a private dwelling are rented to outsiders, these shall be for accommodating not more than three persons per room.

If sleeping accommodation for more than 20 persons is provided in any one residential building, it shall be classified as a building in sub-division A-1, A-3 or A-4 as the case may be.

c) *Sub-division A-3 Dormitories* — These shall include any building in which group sleeping accommodation is provided, with or without dining facilities for persons who are not members of the same family, in one room or a series of closely associated rooms under joint occupancy and single management, for example, school and college dormitories, students, and other hostels and military barracks.

d) *Sub-division A-4 Apartment houses (flats)* — These shall include any building or structure in which living quarters are provided for three or more families, living independently of each other and with independent cooking facilities, for example, apartment houses, mansions and chawls.

e) *Sub-division A-5 Hotels* — These shall include any building or group of buildings under single management, in which sleeping accommodation is provided, with or without dining facilities for hotels classified up to 4 Star Category.

- f) *Sub-division A-6 Hotels (starred)* — These shall include the hotels duly approved by the concerned authorities as Five Star and above Hotels.

3.1.3 Group B Educational Buildings

These shall include any building used for school, college, other training institutions for day-care purposes involving assembly for instruction, education or recreation for not less than 20 students.

Buildings and structures under Group B shall be further sub-divided as follows:

Sub-division B-1 Schools up to senior secondary level

Sub-division B-2 All others/training institutions

- a) *Sub-division B-1 Schools up to senior secondary level* — This sub-division shall include any building or a group of buildings under single management which is used for students not less than 20 in number.
- b) *Sub-division B-2 All others/training institutions* — This sub-division shall include any building or a group of buildings under single management which is used for students not less than 100 in number.

In the case of temporary buildings/structures which are utilized for educational purposes, the provisions of 3.2.5.3 shall apply.

If residential accommodation is provided in the schools/institutions, that portion of occupancy shall be classified as a building in sub-division A-3.

3.1.4 Group C Institutional Buildings

These shall include any building or part thereof, which is used for purposes, such as medical or other treatment or care of persons suffering from physical or mental illness, disease or infirmity, care of infants, convalescents or aged persons and for penal or correctional detention in which the liberty of the inmates is restricted. Institutional buildings ordinarily provide sleeping accommodation for the occupants.

Buildings and structures under Group C shall be further sub-divided as follows:

Sub-division C-1 Hospitals and sanatoria

Sub-division C-2 Custodial institutions

Sub-division C-3 Penal and mental institutions

- a) *Sub-division C-1 Hospitals and sanatoria* — This sub-division shall include any building or a group of buildings under single management, which is used for housing persons suffering from physical limitations because of health or age, for example, hospitals, infirmaries, sanatoria and nursing homes.

- b) *Sub-division C-2 Custodial institutions* — This sub-division shall include any building or a group of buildings under single management, which is used for the custody and care of persons, such as children, convalescents and the aged, for example, homes for the aged and infirm, convalescent homes and orphanages.

- c) *Sub-division C-3 Penal and mental institutions* — This sub-division shall include any building or a group of buildings under single management, which is used for housing persons under restraint, or who are detained for penal or corrective purposes, in which the liberty of the inmates is restricted, for example, jails, prisons, mental hospitals, mental sanatoria and reformatories.

3.1.5 Group D Assembly Buildings

These shall include any building or part of a building, where number of persons not less than 50 congregate or gather for amusement, recreation, social, religious, patriotic, civil, travel and similar purposes, for example, theatres, motion picture houses, assembly halls, auditoria, exhibition halls, museums, skating rinks, gymnasiums, restaurants, places of worship, dance halls, club rooms, passenger stations and terminals of air, surface and marine public transportation services, recreation piers and stadia, etc.

Buildings under Group D shall be further sub-divided as follows:

Sub-division D-1 Buildings having a theatrical or motion picture or any other stage and fixed seats for over 1 000 persons

Sub-division D-2 Buildings having a theatrical or motion picture or any other stage and fixed seats upto 1 000 persons

Sub-division D-3 Buildings without a permanent stage having accommodation for 300 or more persons but no permanent seating arrangement.

Sub-division D-4 Buildings without a permanent stage having accommodation for less than 300 persons with no permanent seating arrangement.

Sub-division D-5 All other structures including temporary structures designed for assembly of people not covered by sub-divisions D-1 to D-4, at ground level.

Sub-division D-6 Buildings having mixed occupancies providing facilities such as shopping, cinema theatres, and restaurants.

Sub-division D-7 All other structures, elevated or underground, for assembly of people not covered by sub-divisions D-1 to D-6.

- a) *Sub-division D-1* — This sub-division shall

include any building primarily meant for theatrical or operatic performances and exhibitions and which has a raised stage, proscenium curtain, fixed or portable scenery or scenery loft, lights, motion picture houses, mechanical appliances or other theatrical accessories and equipment and which is provided with fixed seats for over 1 000 persons.

- b) *Sub-division D-2* — This sub-division shall include any building primarily meant for use as described for sub-division D-1, but with fixed seats up to 1 000 persons.
- c) *Sub-division D-3* — This sub-division shall include any building, its lobbies, rooms and other spaces connected thereto, primarily intended for assembly of people, but which has no theatrical stage or permanent theatrical and/or cinematographic accessories and has accommodation for 300 persons or more, for example, dance halls, night clubs, halls for incidental picture shows, dramatic, theatrical or educational presentation, lectures or other similar purposes having no theatrical stage except a raised platform and used without permanent seating arrangement; art galleries exhibition halls, community halls, marriage halls, places of worship, museums, lecture halls, ~~passenger terminals~~ and Heritage and Archeological Monuments.
- d) *Sub-division D-4* — This sub-division shall include any building primarily intended for use as described in sub-division D-3, but with accommodation for less than 300 persons with no permanent seating arrangements.
- e) *Sub-division D-5* — This sub-division shall include any building or structure permanent or temporary meant for assembly of people not covered by sub-divisions D-1 to D-4, for example, grandstands, stadia, amusement park structures, reviewing stands and circus tents.
- f) *Sub-division D-6* — This sub-division shall include any building for assembly of people provided with multiple services/facilities like shopping, cinema theatres and restaurants, for example, multiplexes.
- g) *Sub-division D-7* — This sub-division shall include any building or structure permanent or temporary meant for assembly of people not covered by D-1 to D-6, for example, underground or ~~elevated railways~~.

3.1.6 ~~Group E Business Buildings~~

These shall include any building or part of a building which is used for transaction of business (other than that covered by Group F and part of buildings covered

by 3.1.1.1); for keeping of accounts and records and similar purposes, professional establishments, service facilities, etc. City halls, town halls, court houses and libraries shall be classified in this group so far as the principal function of these is transaction of public business and keeping of books and records.

Business buildings shall be further sub-divided as follows:

~~Sub-division E-1~~ Offices, banks, professional establishments, like offices of architects, engineers, doctors, lawyers and police stations.

Sub-division E-2 Laboratories, research establishments, libraries and test houses.

Sub-division E-3 Computer installations.

Sub-division E-4 Telephone exchanges.

Sub-division E-5 Broadcasting stations and T.V. stations.

3.1.7 Group F Mercantile Buildings

These shall include any building or part of a building, which is used as shops, stores, market, for display and sale of merchandise, either wholesale or retail.

Mercantile buildings shall be further sub-divided as follows:

Sub-division F-1 Shops, stores, departmental stores markets with area up to 500 m².

Sub-division F-2 Shops, stores, departmental stores markets with area more than 500 m².

Sub-division F-3 Underground shopping centres.

Storage and service facilities incidental to the sale of merchandise and located in the same building shall be included under this group.

3.1.8 Group G Industrial Buildings

These shall include any building or part of a building or structure, in which products or materials of all kinds and properties are fabricated, assembled, manufactured or processed, for example, assembly plants, industrial laboratories, dry cleaning plants, power plants, generating units, pumping stations, fumigation chambers, laundries, buildings or structures in gas plants, refineries, dairies and saw-mills, etc.

Buildings under Group G shall be further sub-divided as follows:

Sub-division G-1 Buildings used for low hazard industries.

Sub-division G-2 Buildings used for moderate hazard industries.

Sub-division G-3 Buildings used for high hazard industries.

The hazard of occupancy, for the purpose of the Code, shall be the relative danger of the start and spread of

fire, the danger of smoke or gases generated, the danger of explosion or other occurrences potentially endangering the lives and safety of the occupants of the buildings.

Hazard of occupancy shall be determined by the Authority on the basis of the fire loads of the contents, and the processes or operations conducted in the building, provided, however, that where the combustibility of the material, the flame spread rating of the interior finish or other features of the building or structure are such as to involve a hazard greater than the occupancy hazard, the greater degree of hazard shall govern the classification.

For determination of fire loads and fire load density for arriving at the classification of occupancy hazard, guidance including the calorific values of some common materials, is given at Annex A.

A broad classification of industrial and non-industrial occupancies into low, moderate and high hazard classes is given at Annex B, for guidance. Any occupancy not covered in Annex B, shall be classified in the most appropriate class depending on the degree of hazard.

Where different degrees of hazard of occupancy exist in different parts of a building, the most hazardous of those shall govern the classification for the purpose of this Code, except in cases where hazardous areas are segregated or protected as specified in the Code.

- a) *Sub-division G-1* — This sub-division shall include any building in which the contents are of such comparative low combustibility and the industrial processes or operations conducted therein are of such a nature that there are hardly any possibilities for any self propagating fire to occur and the only consequent danger to life and property may arise from panic, fumes or smoke, or fire from some external source.
- b) *Sub-division G-2* — This sub-division shall include any building in which the contents or industrial processes or operations conducted therein are liable to give rise to a fire which will burn with moderate rapidity or result in other hazardous situation and may give off a considerable volume of smoke, but from which neither toxic fumes nor explosions are to be feared in the event of fire.
- c) *Sub-division G-3* — This sub-division shall include any building in which the contents or industrial processes or operations conducted therein are liable to give rise to a fire which will burn with extreme rapidity or result in other hazardous situation or from which poisonous fumes or explosions are to be feared in the event of a fire. For fire safety in petroleum and fertilizer plant, good practice [4(3)] may be referred.

3.1.9 *Group I-I Storage Buildings*

These shall include any building or part of a building used primarily for the storage or sheltering (including servicing, processing or repairs incidental to storage) of goods, ware or merchandise (except those that involve highly combustible or explosive products or materials) vehicles or animals, for example, warehouses, cold storage, freight depots, transit sheds, storehouses, truck and marine terminals, garages, hangers, grain elevators, barns and stables. Storage properties are characterized by the presence of relatively small number of persons in proportion to the area. Any new use which increase the number of occupants to a figure comparable with other classes of occupancy shall change the classification of the building to that of the new use, for example, hangars used for assembly purposes, warehouses used for office purposes, garage buildings used for manufacturing.

3.1.10 *Group J Hazardous Buildings*

These shall include any building or part of a building which is used for the storage, handling, manufacture or processing of highly combustible or explosive materials or products which are liable to burn with extreme rapidity and or which may produce poisonous fumes or explosions for storage, handling, manufacturing or processing which involve highly corrosive, toxic or noxious alkalis, acids or other liquids or chemicals producing flame, fumes and explosive, poisonous, irritant or corrosive gases; and for the storage, handling or processing of any material producing explosive mixtures of dust which result in the division of matter into fine particles subject to spontaneous ignition. Examples of buildings in this class are those buildings which are used for:

- a) Storage, under pressure of more than 0.1 N/mm² and in quantities exceeding 70 m³, of acetylene, hydrogen, illuminating and natural gases, ammonia, chlorine, phosgene, sulphur dioxide, carbon dioxide, methyloxide and all gases subject to explosion, fume or toxic hazard, cryogenic gases, etc;
- b) Storage and handling of hazardous and highly flammable liquids, liquefiable gases like LPG, rocket propellants, etc;
- c) Storage and handling of hazardous and highly flammable or explosive materials (other than liquids); and
- d) Manufacture of artificial flowers, synthetic leather, ammunition, explosives and fireworks.

NOTE — A list of hazardous substances giving quantities, for which or exceeding which owners handling such substances are required to be covered under the Public Liability Insurance Act, has been notified under Government of India, Ministry of Environment and Forests Notification No. G.S.R. 347(E) dated 1 August 1996.

3.1.11 Any building not covered by Annex B or 3.1.8 shall be classified in the group which most nearly resembles its existing or proposed use.

3.1.12 Where change in the occupancy of any building places it in a different group or in a different sub-division of the same group, such building shall be made to comply with the requirements of the Code for the new group or its sub-division.

3.1.13 Where the new occupancy of a building is less hazardous, based on life and fire risk, than its existing occupancy, it shall not be necessary to conform to the requirements of the Code for the new group or its sub-division.

3.1.14 A certificate of occupancy shall be necessary, as required under Part 2 'Administration', before any change is effected in the character of occupancy of any building.

3.2 Fire Zones

3.2.1 Demarcation

The city or area under the jurisdiction of the Authority shall for the purpose of the Code, be demarcated into distinct zones, based on fire hazard inherent in the buildings and structures according to occupancy (see 3.1), which shall be called as 'Fire Zones'.

3.2.2 Number and Designation of Fire Zones

3.2.2.1 The number of fire zones in a city or area under the jurisdiction of the Authority depends upon the existing layout, types of building construction (see 3.3), classification of existing buildings based on occupancy (see 3.1) and expected future development of the city or area. In large cities or areas, three fire zones may be necessary, while in smaller ones, one or two may be adequate.

3.2.2.2 The fire zones shall be made use of in land use development plan and shall be designated as follows:

- a) *Fire Zone No. 1* — This shall comprise areas having residential (Group A), educational (Group B), institutional (Group C), and assembly (Group D), small business (Sub-divisions E-1) and retail mercantile (Group F) buildings, or areas which are under development for such occupancies.
- b) *Fire Zone No. 2* — This shall comprise business (Sub-divisions E-2 to E-5) and industrial buildings (Sub-division G-1 and G-2), except high hazard industrial buildings (Sub-division G-3) or areas which are under development for such occupancies.
- c) *Fire Zone No. 3* — This shall comprise areas having high hazard industrial buildings (Sub-division G-3), storage buildings (Group H) and buildings for hazardous used (Group J)

or areas which are under development for such occupancies.

3.2.3 Change in the Fire Zone Boundaries

When the boundaries of any fire zone are changed, or when it is intended to include other areas or types of occupancies in any fire zone, it shall be done by following the same procedure as for promulgating new rules or ordinances or both.

3.2.4 Overlapping Fire Zones

3.2.4.1 When any building is so situated that it extends to more than one fire zone, it shall be deemed to be in the fire zone in which the major portion of the building or structure is situated.

3.2.4.2 When any building is so situated that it extends equally to more than one fire zone, it shall be deemed to be in the fire zone having more hazardous occupancy buildings.

3.2.5 Temporary Buildings or Structures

3.2.5.1 Temporary buildings and structures shall be permitted only in Fire Zones No. 1 and 2 as the case may be, according to the purpose for which these are to be used, by special permit from the Authority for a limited period and subject to such conditions as may be imposed in the permit.

3.2.5.2 Such buildings and temporary structures shall be completely removed on the expiry of the period specified in the permit.

3.2.5.3 Adequate fire precautionary measures in the construction of temporary structures and *PANDALS* shall be taken in accordance with good practice [4(4)].

3.2.6 Restrictions on the Type of Construction for New Buildings

3.2.6.1 Buildings erected in Fire Zone No. 1 shall conform to construction of Type 1, 2, 3 or 4.

3.2.6.2 Buildings erected in Fire Zone No. 2 shall conform to construction of Type 1, 2 or 3.

3.2.6.3 Buildings erected in Fire Zone No. 3 shall conform to construction of Type 1 or 2.

3.2.7 Restrictions on Existing Buildings

The existing buildings in any fire zone shall not be required to comply with the requirement of the Code unless these are altered, or in the opinion of the Authority, such building constitutes a hazard to the safety of the adjacent property or the occupants of the building itself or is an unsafe building. In the event of alteration, it shall be necessary to obtain permission of the Authority for such alteration consistent with fire hazard (see Part 2 'Administration').

Alterations/modifications/renovations shall be accomplished so as to ensure conformity with all the

safety requirements of the new buildings. Such alterations shall not in anyway bring down level of fire and life safety below that which existed earlier. Any addition or alterations or construction of cubicles or partitioning for floor area exceeding 500 m² for all high rise buildings shall be with approval of local fire authority.

3.3 Types of Construction

3.3.1 General

The design of any building and the type of materials used in its construction are important factors in making the building resistant to a complete burn-out and in preventing the rapid spread of fire, smoke or fumes, which may otherwise contribute to the loss of lives and property.

The fire resistance of a building or its structural and non-structural elements is expressed in hours against a specified fire load which is expressed in kcal/m², and against a certain intensity of fire. The fire-resistance test for structural element shall be done in accordance with good practice [4(5)]. For the purpose of the Code, the types of construction according to fire resistance shall be classified into four categories, namely,

Type 1 Construction, Type 2 Construction, Type 3 Construction and Type 4 'Construction'. The fire resistance ratings for various types of construction for structural and non-structural members shall be as given in Table 1.

For buildings 15 m in height or above non-combustible materials should be used for construction and the internal walls of staircase enclosures should be of brick work or reinforced concrete or any other material of construction with minimum of 2 h rating. The walls for the chimney shall be of Type 1 and Type 2 Construction depending on whether the gas temperature is above 200°C or less.

3.3.2 It is required that an element/component shall have the requisite fire resistance rating when tested in accordance with the accepted standard [4(1)]. Tables 2 to 18 provide available data regarding fire resistance ratings of various building components such as walls, columns, beams and floors. Fire damage assessment, post fire structural safety assessment of various structural elements of the building and adequacy of the structural repairs can be done by the fire resistance ratings mentioned in Tables 2 to 18.

Table 1 Fire Resistance Ratings of Structural and Non-Structural Elements (Hours)

(Clause 3.3.1)

Sl No.	Structural Element	Type of Construction				
		Type 1	Type 2	Type 3	Type 4	
(1)	(2)	(3)	(4)	(5)	(6)	
i)	Exterior walls:					
a)	Fire separation less than 3.7 m	a) Bearing	4	2	2	1
		b) Non-bearing	2	1½	1	1
b)	Fire separation of 3.7 m or more but less than 9 m	a) Bearing	4	2	2	1
		b) Non-bearing	1½	1	1	1
c)	Fire separation of 9 m or more	a) Bearing	4	2	2	1
		b) Non-bearing	1	1	1	1
ii)	Fire resisting walls		4	2	2	2
iii)	Fire separation assemblies (like fire check doors)		4	2	2	2
iv)	Fire enclosures of exitways, hallways and stairways		2	2	2	2
v)	Shaft other than exitways, elevator and hoistways		2	2	2	2
vi)	Exitway access corridors		1	1	1	1
vii)	Vertical separation of tenant spaces		1	1	1	1
viii)	Dwelling unit separation		1	1	1	1
	Non-load bearing partitions		— At least half an hour —			
ix)	Interior bearing walls, bearing partitions, columns, girders, trusses (other than roof trusses) and framing	a) Supporting more than one floor	4	2	2	2
		b) Supporting one floor only	3	1½	1	1
		c) Supporting a roof only	3	1½	1	1
x)	Structural members support walls		3	1½	1	1
xi)	Floor construction including walls		3	1½	1	1
xii)	Roof construction	a) 5 m or less in height to lowest member	2	1½	1	1
		b) More than 5 m but less than 6.7 m in height to lowest member	1	1	1	1
		c) 6.7 m or more in height to lowest member	0	0	0	0

Table 2 Masonry Walls: Solid (Required to Resist Fire from One Side at a Time)
(Clause 3.3.2)

SI No.	Nature of Construction and Materials	Minimum Thickness (mm), Excluding any Finish for a Fire Resistance (Hours) of										
		Load Bearing					Non-load Bearing					
		1	1½	2	3	4	1	1½	2	3	4	
(1)	(2)	(3)	(4)	(5)	(6)	(7)	(8)	(9)	(10)	(11)	(12)	
i)	Reinforced ¹⁾ cement concrete	120 (25) ²⁾	140 (25) ²⁾	160 (25) ²⁾	200 (25) ²⁾	240 (25) ²⁾						
ii)	Unreinforced cement concrete	150	175	—	—	—						
iii)	No-fines concrete with :											
	a) 13 mm cement/sand or gypsum/sand	—	—	—	—	—	150	150	150	150	150	150
	b) 13 mm light weight aggregate gypsum plaster	—	—	—	—	—	150	150	150	150	150	150
iv)	Bricks of clay:											
	a) Without finish	90	100	100	170	170	75	90	100	170	170	170
	b) With 13 mm lightweight aggregate gypsum plaster	90	90	90	100	100	75	90	90	90	90	100
v)	Bricks of sand lime:											
	a) Without finish	90	100	100	190	190	75	90	100	170	170	170
	b) With 13 mm lightweight aggregate gypsum plaster	90	90	90	100	100	75	90	90	90	90	100
vi)	Blocks of concrete:											
	a) Without finish	90	100	100	—	—	75	90	100	140	150	150
	b) With 13 mm lightweight aggregate gypsum plaster	90	90	90	100	100	75	75	75	90	100	100
	c) With 13 mm cement/sand or gypsum/sand	—	—	—	—	—	75	90	90	100	140	150
vii)	Blocks of lightweight concrete:											
	a) Without finish	90	100	100	140	150	75	75	75	125	140	140
	b) With 13 mm lightweight aggregate gypsum plaster	90	90	90	100	100	50	63	75	75	75	75
	c) With 13 mm cement/sand or gypsum/sand	—	—	—	—	—	75	75	75	90	100	100
viii)	Blocks of aerated concrete:											
	a) Without finish	90	100	100	140	180	50	63	63	75	100	100
	b) With 13 mm lightweight aggregate gypsum plaster	90	90	100	100	150	50	63	63	75	100	100

¹⁾ Walls containing at least 1 percent of vertical reinforcement.

²⁾ Minimum thickness of actual cover to reinforcement.

Table 3 Masonry Walls: Hollow (Required to Resist Fire from One Side at a Time)
(Clause 3.3.2)

SI No.	Nature of Construction and Materials	Minimum Thickness (mm), Excluding any Finish for a Fire Resistance (Hours) of											
		Load Bearing					Non-load Bearing						
		1	1½	2	3	4	½	1	1½	2	3	4	
(1)	(2)	(3)	(4)	(5)	(6)	(7)	(8)	(9)	(10)	(11)	(12)	(13)	
i)	Bricks of clay:												
	a) Without finish	170	170	170	200	200	75	75	90	100	170	170	170
	b) With 13 mm lightweight aggregate gypsum plaster	100	100	170	170	170	75	75	90	90	90	100	100
ii)	Blocks of concrete:												
	a) Without finish	—	—	—	—	—	90	125	125	140	140	150	150
	b) With 13 mm cement/sand or gypsum/sand	190	200	200	—	—	90	125	125	140	140	140	140
	c) With 13 mm lightweight aggregate gypsum plaster	—	—	—	—	—	75	90	90	100	125	125	125
iii)	Blocks of lightweight concrete:												
	a) Without finish	100	100	100	—	—	75	90	90	100	140	150	150
	b) With 13 mm cement/sand or gypsum/sand	—	—	—	—	—	75	75	75	100	140	140	140
	c) With 13 mm lightweight aggregate gypsum plaster	—	—	—	—	—	63	63	63	75	90	100	100

Table 4 Framed Construction, Load Bearing (Required to Resist Fire from One Side at a Time)
(Clause 3.3.2)

Sl No.	Nature of Construction and Materials/Timber Studs at Centres not Exceeding 600 mm, Faced on Each Side with	Minimum Thickness (mm) of Protection for a Fire Resistance of 1h
(1)	(2)	(3)
i)	Plasterboard layers with joints staggered, joints in outer layer taped and filled — Total thickness for each face	25
ii)	One layer of 12.7 mm plasterboard with a finish of lightweight aggregate gypsum plaster	13
iii)	Metal lath and plaster, thickness of plaster:	
a)	Sanded gypsum plaster (metal lathing grade)	22
b)	Lightweight aggregate gypsum plaster	13

Table 5 Framed Construction, Non-Load Bearing (Required to Resist Fire from One Side at a Time)
(Clause 3.3.2)

Nature of Construction and Materials/Steel or Timber Frame at Centres not Exceeding 600 mm, Facings on Both Sides of	Stud Construction	Minimum Thickness (mm) of Protection for a Fire Resistance			
		½ h	1 h	1½ h	2 h
(1)	(2)	(3)	(4)	(5)	(6)
A) Dry lining with materials fixed direct to studs (without plaster finish)					
1. One layer of plasterboard with taped and filled joints	Timber or steel	12.7			
2. Two layers of plasterboard with joints staggered, joints in outer layer taped and filled — Total thickness for each face	Timber or steel	19	25		
3. One layer of asbestos insulating board with transverse joints backed by fillers of asbestos insulating board not less than 9 mm thick, or by timber	Timber or steel	9	12		
4. One layer of wood wool slabs	Timber	25			
5. One layer of chipboard or of plywood	Timber or steel	18			
B) Lining with materials fixed direct to studs, with plaster finish:					
Plasterboard of thickness:					
a) With not less than 5 mm gypsum plaster finish	Timber or steel	9.5			
b) With not less than 13 mm gypsum plaster finish			12.7		
C) Wet finish:					
Metal lath and plaster, thickness of plaster:					
a) Sanded gypsum plaster	Timber or steel	13			
b) Lightweight aggregate gypsum plaster	Timber		13	19	25
	Steel		13		

Table 6 Framed External Walls Load Bearing (Required to Resist Fire from One Side at a Time)
(Clause 3.3.2)

Sl No.	Nature of Construction and Materials	Minimum Thickness (mm) of Protection for a Fire Resistance of 1 h
(1)	(2)	(3)
	Timber studs at centers not exceeding 600 mm with internal linings of :	
i)	Plasterboard layers with joints in outer layer taped and filled, total thickness of plasterboard	25

Table 7 Framed External Walls Non-Load Bearing Required to Resist Fire only from Inside the Building (A)

(Clause 3.3.2)

Nature of Construction and Materials (1)	Minimum Thickness (mm) of Protection for a Fire Resistance					
	½ h	1 h	1½ h	2 h	3 h	4 h
	(2)	(3)	(4)	(5)	(6)	(7)
Steel frame with an external cladding of non-combustible sheets (excluding sheet steel), with a steel supporting framework and internal lining of:						
1. Metal lath and plaster, thickness of plaster:						
a) Sanded gypsum plaster (metal lathing grade)	13	13				
b) Lightweight aggregate gypsum plaster	10	13	15	15	15	19
2. Two layer of plasterboard with joints staggered joints in outer layer taped and filled — Total thickness	21	32				
3. Plasterboard of thickness:						
a) With not less than 5 mm gypsum plaster finish	12.7					
b) With not less than 13 mm gypsum plaster finish	9.5					
c) With not less than 10 mm lightweight aggregate gypsum plaster	9.5					
4. One layer of asbestos insulating board with transverse joints backed by fillers of asbestos insulating board not less than 9 mm thick, or by timber	9	9	12	12	12	12
5. One layer of wood/wool slabs without finish		50				
6. One layer of compressed straw building slabs:						
a) Without finish	50					
b) With not less than 5 mm gypsum plaster finish		50				
7. Aerated concrete blocks	50	50	63	63	75	100
8. Bricks of clay:						
a) Without finish	75	75	90	90	100	100
b) With not less than 13 mm lightweight aggregate gypsum plaster			75	75	90	90

Table 8 Framed External Walls Non-Load Bearing Required to Resist Fire only from Inside the Building (B)

(Clause 3.3.2)

Nature of Construction and Materials (1)	Minimum Thickness (mm) of Protection to Provide Sufficient Insulation to Achieve a Modified Fire Resistance of Up to 4 h (2)
Steel frame with an external cladding of sheet steel fully lapped, steel bolted and fixed to steel sheeting rails, with timber or steel supporting framework and internal lining of:	
1. Metal lath and plaster, thickness of plaster:	
a) Sanded gypsum plaster (metal lathing grade)	13
b) Lightweight aggregate gypsum plaster	10
2. One layer of plasterboard with joints taped and filled	12.7
3. Plasterboard of thickness with not less than 5 mm gypsum plaster finish	9.5
4. One layer of asbestos insulating board with transverse joints backed by fillers of asbestos insulating board not less than 9 mm thick, or by timber	9
5. One layer of wood/wool slabs	25
6. One layer of compressed straw building slabs	50
7. One layer of chipboard or of plywood	18
8. Aerated concrete blocks	50
9. Bricks of clay	75
10. Any internal decorative lining with a cavity fill independently supported and retained in position of mineral fibre insulating material (excluding glass) at a density of 48 kg/m ³	50

Table 9 Framed Walls Non-Load Bearing Required to Resist Fire only from Inside the Building (C)
(Clause 3.3.2)

Nature of Construction and Materials (1)	Minimum Thickness (mm) of Protection for a Fire Resistance of 1½ h (2)
Timber frame with external cladding of weather boarding or external plywood, 9.5 mm with an internal lining of:	
1. Plasterboard not less than 9.5 mm thick, finished with:	
a) Gypsum plaster	13
b) Lightweight aggregate gypsum plaster	10
2. Plasterboard not less than 12.7 mm thick, finished with:	
a) Gypsum plaster	10
b) Lightweight aggregate gypsum plaster	10
3. One layer of asbestos insulating board with transverse joints backed by fillers of asbestos insulating board not less than 9 mm thick, or by timber	9 12

Table 10 Reinforced Concrete Columns
(Clause 3.3.2)

Sl No.	Nature of Construction and Materials		Minimum Dimensions (mm) Excluding any Finish, for a Fire Resistance of					
			½ h	1 h	1½ h	2 h	3 h	4 h
(1)	(2)		(3)	(4)	(5)	(6)	(7)	(8)
i)	Fully exposed	Width	150	200	250	300	400	450
		Cover	40	40	40	40	40	40
ii)	50 percent exposed	Width	125	160	200	200	300	350
		Cover	40	40	40	40	40	40
iii)	One face exposed	Thickness	100	120	140	160	200	240
		Cover	40	40	40	40	40	40

Table 11 Concrete Beams
(Clause 3.3.2)

Sl No.	Nature of Construction and Materials		Minimum Dimensions (mm) Excluding any Finish, for a Fire Resistance of					
			½ h	1 h	1½ h	2 h	3 h	4 h
(1)	(2)		(3)	(4)	(5)	(6)	(7)	(8)
i)	Reinforced concrete (simply supported)	Width	200	200	200	200	240	280
		Cover	20	20	20	40	60 ^{b)}	70 ^{b)}
ii)	Reinforced concrete (continuous)	Width	200	200	200	200	240	280
		Cover	20	20	20	30	40	50 ^{b)}
iii)	Prestressed concrete (simply supported)	Width	100	120	150	200	240	280
		Cover	25	40	55	70	80	90
iv)	Prestressed concrete (continuous)	Width	80	100	120	150	200	240
		Cover	20	30	40	55	70	80

^{b)} Require attention to the additional measures necessary to reduce the risk of spalling.

Table 12 Concrete Floors
(Clause 3.3.2)

Sl No.	Nature of Construction and Materials		Minimum Dimensions (mm) Excluding any Finish, for a Fire Resistance of					
			½ h	1 h	1½ h	2 h	3 h	4 h
(1)	(2)		(3)	(4)	(5)	(6)	(7)	(8)
i)	Reinforced concrete (simply supported)	Thickness	75	95	110	125	150	170
		Cover	20	20	25	35	45 ^{b)}	55 ^{b)}
ii)	Reinforced concrete (continuous)	Thickness	75	95	110	125	150	170
		Cover	20	20	20	25	35	45 ^{b)}

^{b)} Require attention to the additional measures necessary to reduce the risk of spalling.

Table 13 Concrete Floors: Ribbed Open Soffit

(Clause 3.3.2)

Sl No.	Nature of Construction and Materials		Minimum Dimensions (mm) Excluding any Finish, for a Fire Resistance of					
			½ h	1 h	1½ h	2 h	3 h	4 h
(1)	(2)		(3)	(4)	(5)	(6)	(7)	(8)
i)	Reinforced concrete (simply supported)	Thickness of floor	75	95	110	125	150	170
		Rib width	125	125	125	125	150	175
		Cover	20	20	35	45	55	65
ii)	Reinforced concrete (continuous)	Thickness	75	95	110	125	150	170
		Width	125	125	125	125	150	175
		Cover	20	20	20	35	45	55

Table 14 Encased Steel Columns, 203 mm × 203 mm

(Protection Applied on Four Sides)

(Clause 3.3.2)

(1)	Minimum Dimensions (mm) Excluding any Finish, for a Fire Resistance of				
	1 h	1½ h	2 h	3 h	4 h
(1)	(2)	(3)	(4)	(5)	(6)
A) Hollow protection (without an air cavity over the flanges):					
1.	1) Metal lathing with trowelled lightweight aggregate gypsum plaster				
	13	15	20	32	
2.	Plasterboard with 1.6 mm wire binding at 100 mm pitch, finished with lightweight aggregate gypsum plaster not less than the thickness specified:				
a)	9.5 mm plaster board	10	15		
b)	19 mm plaster board			10	13
3.	Asbestos insulating boards, thickness of board:				
a)	Single thickness of board, with 6 mm cover fillets at transverse joints		19	25	
b)	Two layers, of total thickness				38
4.	Solid bricks of clay, composition or sand lime, reinforced in every horizontal joint, unplastered				
	50	50	50	75	100
5.	Aerated concrete blocks				
	60	60	60		
6.	Solid blocks of lightweight concrete hollow protection (with an air cavity over the flanges)				
	50	50	50	60	75
B)	Asbestos insulating board screwed to 25 mm asbestos battens				
	12	19			
C) Solid protections					
1.	Concrete, not leaner than 1:2:4 mix (unplastered):				
a)	Concrete not assumed to be load bearing, reinforced ²⁾	25	25	25	50
b)	Concrete assumed to be load bearing	50	50	50	75
2.	Lightweight concrete, not leaner than 1:2:4 mix (unplastered): concrete not assumed to be load bearing, reinforced ²⁾				
	25	25	25	40	60

¹⁾ So fixed or designed, as to allow full penetration for mechanical bond.

²⁾ Reinforcement shall consist of steel binding wire not less than 2.3 mm in thickness, or a steel mesh weighing not less than 0.5 kg/m². In concrete protection, the spacing of that reinforcement shall not exceed 200 mm in any direction.

Table 15 Encased Steel Beams, 406 mm x 176 mm (Protection Applied on Three Sides)
(Clause 3.3.2)

Nature of Construction and Materials (1)	Minimum Thickness (mm) of Protection for a Fire Resistance of					
	½ h (2)	1 h (3)	1½ h (4)	2 h (5)	3 h (6)	4 h (7)
A) Hollow protection (without an air cavity beneath the lower flange):						
1. ¹⁾ Metal lathing with trowelled lightweight aggregate gypsum plaster	13	13	15	20	25	
2. Plasterboard with 1.6 mm wire binding ²⁾ at 100 mm pitch, finished with lightweight aggregate gypsum plaster not less than the thickness specified:						
a) 9.5 mm plaster board	10	10	15			
b) 19 mm plaster board	10	10		13	20	
3. Asbestos insulating boards, thickness of board:						
a) Single thickness of board, with 6 mm cover fillets at transverse joints			19	25		
b) Two layers, of total thickness					38	50
B) Hollow protection (with an air cavity below the lower flange):						
1. Asbestos insulating board screwed to 25 mm asbestos battens	9	12				
C) Solid protection:						
1. Concrete, not leaner than 1:2:4 mix (unplastered):						
a) Concrete not assumed to be load bearing, reinforced ³⁾	25	25	25	25	50	75
b) Concrete assumed to be load bearing	50	50	50	50	75	75
2. Lightweight concrete ⁴⁾ , not leaner than 1:2:4 (mix) unplastered	25	25	25	25	40	60

¹⁾ So fixed or designed, as to allow full penetration for mechanical bond.

²⁾ Where wire binding cannot be used, expert advice should be sought regarding alternative methods of support to enable the lower edges of the plasterboard to be fixed together and to the lower flange, and for the top edge of the plasterboard to be held in position.

³⁾ Reinforcement shall consist of steel binding wire not less than 2.3 mm in thickness or a steel mesh weighing not less than 0.5 kg/m². In concrete protection, the spacing of that reinforcement shall not exceed 200 mm in any direction.

⁴⁾ Concrete not assumed to be load bearing, reinforced.

Table 16 Timber Floors — Tongued and Grooved Boarding, or Sheets of Tongued and Grooved Plywood or Wood Chipboard, of not Less than 21 mm Finished Thickness
(Clause 3.3.2)

Nature of Construction and Materials (1)	Minimum Thickness (mm) of Protection for a Fire Resistance of		
	½ h (2)	1 h (3)	2 h (4)
37 mm (minimum) timber joists with a ceiling of:			
1. Timber lathing and plaster, plaster of thickness	15		
2. Metal lathing and plaster, thickness of plaster:			
a) Sanded gypsum plaster (metal lathing grade)	15		
b) Lightweight aggregate gypsum plaster	13	13	25
3. One layer of plasterboard with taped and filled joints	12.7		
4. Two layers of plasterboard with joints staggered, joints in outer layer taped and filled total thickness	19	31	
5. One layer of plasterboard not less than 9.5 mm thick, finished with:			
a) Gypsum plaster	5		
b) Sanded gypsum plaster	13		
c) Lightweight aggregate gypsum plaster	13		
6. One layer of plasterboard not less than 12.7 mm thick, finished with:			
a) Gypsum plaster	5		
b) Lightweight aggregate gypsum plaster	10		
7. One layer of asbestos insulating board with any transverse joints backed by fillets of asbestos insulating board not less than 9 mm thick, or by timber	9	12	

Table 17 Timber Floors — Tongued and Grooved Boarding, or Sheets of Tongued and Grooved Plywood or Wood Chipboard, of not Less than 15 mm Finished Thickness

(Clause 3.3.2)

Nature of Construction and Materials (1)	Minimum Thickness (mm) of Protection for a Fire Resistance of		
	1½ h (2)	1 h (3)	2 h (4)
37 mm (minimum) timber joists with a ceiling of:			
1. Timber lathing and plaster, plaster of thickness	15		
2. Metal lathing and plaster, thickness of plaster for:			
a) Sanded gypsum plaster (metal lathing grade)	15		
b) Lightweight aggregate gypsum plaster	13	13	25
3. One layer of plasterboard with taped and filled joints	12.7		
4. Two layers of plasterboard with joints staggered, joints in outer layer taped and filled total thickness	22	31	
5. One layer of plasterboard not less than 9.5 mm thick, finish with:			
a) Gypsum plaster	5		
b) Sanded gypsum plaster	15		
c) Lightweight aggregate gypsum plaster	13		
6. One layer of plasterboard not less than 12.7 mm thick, finished with:			
a) Gypsum plaster	5		
b) Lightweight aggregate gypsum plaster	10		
7. One layer of asbestos insulating board, with any transverse joints backed by fillets of asbestos insulating board not less than 9 mm thick, or by timber	9	12 ^{b)}	

^{b)} Finished on top with 25 mm minimum thick glass fibre or mineral wool laid between joints.

Table 18 Timber Floors — Any Structurally Suitable Flooring of Timber or Lignocelluloses Boards

(Clause 3.3.2)

Nature of Construction and Materials (1)	Minimum Thickness (mm) of Protection for a Fire Resistance of	
	½ h (2)	1 h (3)
37 mm (minimum) timber joists with a ceiling of:		
1. Timber lathing and plaster, plaster of thickness	15	
2. Metal lathing and plaster, thickness of plaster for:		
a) Sanded gypsum plaster (metal lathing grade)	15	
b) Lightweight aggregate gypsum plaster	13	19
3. One layer of plasterboard with joints taped and filled and backed by timber	12.7	
4. Two layers of plasterboard with joints staggered, joints in outer layer taped and filled total thickness	25	
5. Two layers of plasterboard, each not less than 9.5 mm thick, joints between boards staggered and outer layer finished with gypsum plaster	5	
6. One layer of plasterboard not less than 9.5 mm thick, finish with:		
a) Sanded gypsum plaster	13	
b) Lightweight aggregate gypsum plaster	15	
7. One layer of plasterboard not less than 12.7 mm thick, finished with:		
a) Sanded gypsum plaster	15	
b) Lightweight aggregate gypsum plaster	13	
8. One layer of asbestos insulating board with any transverse joints backed by fillets of asbestos insulating board not less than 9 mm thick, or by timber	12	

3.3.3 Steel Construction

Load bearing steel beams and columns of buildings having total covered area of 500 m² and above shall be protected against failure/collapse of structure in case

of fire. This could be achieved by use of appropriate methodology using suitable fire resistance rated materials alongwith suppression system (see Table 14, Table 15 and also accepted standard [4(5)]).

3.4 General Requirements of All Individual Occupancies

3.4.1 General

All buildings shall satisfy certain requirements which contribute, individually and collectively, to the safety of life from fire, smoke, fumes and panic arising from these or similar causes. There are, however, certain general principles and common requirements which are applicable to all or most of the occupancies.

3.4.2 Exceptions and Deviations

Exceptions and deviations to the general provisions of requirements of individual occupancies are given as applicable to each type of occupancy in 6.1 to 6.9. In case of practical difficulty or to avoid unnecessary hardship, without sacrificing reasonable safety, the Authority may grant exemptions from the Code.

3.4.3 Occupation of Buildings under Construction

3.4.3.1 A building or portion of the building may be occupied during construction, repairs, alterations or additions only if all means of exit and fire protection measures are in place and continuously maintained for the occupied part of the building.

3.4.3.2 A high rise building during construction shall be provided with the following fire protection measures, which shall be maintained in good working condition at all the times:

- Dry riser of minimum 100 mm diameter pipe with hydrant outlets on the floors constructed with a fire service inlet to boost the water in the dry riser and maintenance should be as per the requirements laid down in good practice [4(6)].
- Drums filled with water of 2 000 litres capacity with two fire buckets on each floor; and
- A water storage tank of minimum 20 000 litres capacity, which may be used for other construction purposes also.

3.4.4 Maximum Height

Every building shall be restricted in its height above the ground level and the number of storeys, depending upon its occupancy and the type of construction. The height shall be measured as specified in Part 3 'Development Control Rules and General Building Requirements'. The maximum permissible height for any combination of occupancy and types of construction should necessarily be related to the width of street fronting the building, or floor area ratios and the local fire fighting facilities available.

3.4.5 Floor Area Ratio

The comparative floor area ratios for different occupancies and types of construction are given in

Table 19 (see also Part 3 'Development Control Rules and General Building Requirements').

Table 19 Comparative Floor Area Ratios for Occupancies Facing One Public Street Atleast 9 m Wide
(Clauses 2.6 and 3.4.5)

Occupancy Classification (1)	Type of Construction			
	Type 1 (2)	Type 2 (3)	Type 3 (4)	Type 4 (5)
Residential	UL	2.0	1.4	1.0
Educational	UL	2.0	1.4	1.0
Institutional	UL	1.5	1.0	0.8
Assembly	UL	1.0	0.7	0.5
Business	UL	2.9	2.3	1.6
Mercantile	8.0	1.8	1.4	1.0
Industrial	7.5	1.9	1.6	1.3
Storage (see Note 5)	6.0	1.5	1.3	1.0
Hazardous (see Note 5)	2.8	1.1	0.9	NP

UL — Unlimited.

NP — Not permitted.

NOTES

1 The FAR values given in this table are subject to overall restrictions on the heights of buildings in the case of educational, institutional, assembly, storage and hazardous occupancies as specified in col 2 of Table 23.

2 This table has been prepared, taking into account the combustible content in the different occupancies as well as the fire resistance offered by the type of construction.

3 This table should be modified by the Authority, taking into account the other aspects as given below:

- Density in terms of dwelling units per hectare;
- Traffic considerations;
- Parking spaces;
- Local fire fighting facilities; and
- Water supply, drainage and sanitation requirements.

4 The FAR values specified in this table may be increased by 20 percent for the following services:

- A basement or cellar space under a building constructed on stilts and used as a parking space and air-conditioning plant room used as accessory to the principal use;
- Watchman's booth, pumphouse, garbage shaft, electric cabin or sub-station and other utility structures meant for the services of the building under considerations;
- Projections and accessory buildings as specifically exempted under the Code; and
- Staircase room and lift rooms above the topmost storey; architectural feature; and chimneys and elevated tanks of dimensions as permissible under the Code; the area of the lift shaft shall be taken only on one floor.

5 In so far as single-storey storage and hazardous occupancies are concerned, they would be further governed by volume to plot area ratio (VPR) to be decided by the Authority.

3.4.5.1 Each portion of a building, which is separated by one or more continuous fire resisting walls, having a fire resistance of not less than 2 h, extending from the foundation to 1 m above the roof at all points, may

be considered to be a separate building for the calculation of maximum permissible height and floor area, provided openings, if any, in the separating wall are also protected by fire assemblies of not less than 2 h.

3.4.6 Open Spaces

The open spaces around or inside a building shall conform to the requirements of Part 3 'Development Control Rules and General Building Requirements'.

3.4.6.1 For high rise buildings, the following additional provisions of means of access to the building shall be ensured (see Part 3 'Development Control Rules and General Building Requirements'):

- a) The width of the main street on which the building abuts shall not be less than 12 m and one end of this street shall join another street not less than 12 m in width;
- b) The road shall not terminate in a dead end; except in the case of residential building, up to a height of 30 m.
- c) The compulsory open spaces around the building shall not be used for parking; and
- d) Adequate passageway and clearances required for fire fighting vehicles to enter the premises shall be provided at the main entrance; the width of such entrance shall be not less than 4.5 m. If an arch or covered gate is constructed, it shall have a clear head-room of not less than 5 m.

3.4.7 Mixed Occupancy

When any building is used for more than one type of occupancy, then in so far as fire safety is concerned, it shall conform to the requirements for the occupancies of higher hazard. Unless the high hazard area is separated by separating walls of 4 h rating, the occupancies shall not be treated individually.

3.4.8 Openings in Separating Walls and Floors

At the time of designing openings in separating walls and floors, particular attention shall be paid to all such factors as will limit fire spread through these openings and maintain fire rating of the structural member.

3.4.8.1 For Types 1 to 3 construction, a doorway or opening in a separating wall on any floor shall be limited to 5.6 m² in area with a maximum height/width of 2.75 m. Every wall opening shall be protected with fire-resisting doors having the fire rating of not less than 2 h in accordance with accepted standard [4(7)]. All openings in the floors shall be protected by vertical enclosures extending above and below such openings, the walls of such enclosures having a fire resistance of not less than 2 h and all openings therein being

protected with a fire-resisting assembly as specified in 3.4.9.

3.4.8.2 For Type 4 construction, openings in the separating walls or floors shall be fitted with 2 h fire-resisting assemblies.

3.4.8.3 Openings in walls or floors which are necessary to be provided to allow passages of all building services like cables, electrical wirings, telephone cables, plumbing pipes, etc, shall be protected by enclosure in the form of ducts/shafts having a fire resistance not less than 2 h. The inspection door for electrical shafts/ducts shall be not less than 2 h and for other services shafts/ducts, the same shall have fire resistance not less than 1 h. Medium and low voltage wiring running in shafts/ducts, shall either be armoured type or run through metal conduits. Further, the space between the conduits pipes and the walls/slabs shall be filled in by a filler material having fire resistance rating of not less than 1 h.

NOTE — In the case of buildings where it is necessary to lower or lift heavy machinery or goods from one floor to the other, it may be necessary to provide larger openings in the floor. Such openings shall be provided with removable covers which shall have the same strength and fire resistance as the floor.

3.4.8.4 Vertical opening

Every vertical opening between the floors of a building shall be suitably enclosed or protected, as necessary, to provide the following:

- a) Reasonable safety to the occupants while using the means of egress by preventing spread of fire, smoke, or fumes through vertical openings from floor to floor to allow occupants to complete their use of the means of egress. Further it shall be ensured to provide a clear height of 2 100 mm in the passage/escape path of the occupants.
- b) Limitation of damage to the building and its contents.

3.4.9 Fire Stop or Enclosure of Openings

Where openings are permitted, they shall not exceed three-fourths the area of the wall in the case of an external wall and they shall be protected with fire resisting assemblies or enclosures having a fire resistance equal to that of the wall or floor in which these are situated. Such assemblies and enclosures shall also be capable of preventing the spread of smoke or fumes through the openings so as to facilitate the safe evacuation of building in case of a fire (see also accepted standard [4(8)]).

3.4.10 Electrical Installations

For requirements regarding electrical installations from the point of view of fire safety, reference may be made

to good practice [4(9)] (see also Part 8 'Building Services, Section 2 Electrical and Allied Installations').

3.4.11 Air-conditioning and Ventilation

Air-conditioning and ventilation requirements of different rooms or areas in any occupancy shall be as given in Part 8 'Building Services, Section 1 Lighting and Ventilation and Section 3 Air-conditioning, Heating and Mechanical Ventilation'.

3.4.11.1 Air-conditioning and ventilating systems shall be so installed and maintained as to minimize the danger of spread of fire, smoke or fumes from one floor to other or from outside to any occupied building or structure (see C-1.17).

3.4.11.2 Air-conditioning and ventilating systems circulating air to more than one floor or fire area shall be provided with dampers designed to close automatically in case of fire and thereby preventing spread of fire or smoke and shall be in accordance with the accepted standard [4(10)]. Such a system shall also be provided with automatic controls to stop fans in case of fire, unless arranged to remove smoke from a fire, in which case these shall be designed to remain in operation.

3.4.11.3 Air-conditioning system serving large places of assembly (over 1 000 persons), large departmental stores or hotels with over 100 rooms in a single block shall be provided with effective means for preventing circulation of smoke through the system in the case of a fire in air filters or from other sources drawn into the system, and shall have smoke sensitive devices for actuation in accordance with the accepted standards [4(11)].

3.4.11.4 From fire safety point of view, separate air handling units for the various floors shall be provided so as to avoid the hazards arising from spread of fire and smoke through the air-conditioning ducts. The requirements of air-conditioning ducts shall be in accordance with good practice [4(12)].

3.4.11.5 For normal operation, air changes schedule shall be as given in Part 8 'Building Services, Section 3 Air-conditioning, Heating and Mechanical Ventilation'.

3.4.12 Smoke Venting

3.4.12.1 Smoke venting facilities for safe use of exits in windowless buildings, underground structures, large area factories, hotels and assembly buildings (including cinema halls) shall be automatic in action with manual controls in addition.

3.4.12.2 Natural draft smoke venting shall utilize roof vents or vents in walls at or near the ceiling level; such vents shall be normally open, or, if closed, shall be designed for automatic opening in case of fire, by release of smoke sensitive devices.

3.4.12.3 Where smoke venting facilities are installed for purposes of exit safety, these shall be adequate to prevent dangerous accumulation of smoke during the period of time necessary to evacuate the area served, using available exit facilities with a margin of safety to allow for unforeseen contingencies. It is recommended that smoke exhaust equipment should have a minimum capacity of 12 air changes per hour. Where mechanical venting is employed, it shall be firesafe.

3.4.12.4 The discharge apertures of all natural draft smoke vents shall be so arranged as to be readily accessible for opening by fire service personnel.

3.4.12.5 Power operated smoke exhausting systems shall be substituted for natural draft vents only by specific permission of the Authority.

3.4.13 Heating

Installation of chimney and heating apparatus shall be in accordance with good practice [4(13)].

3.4.14 Additional Precautions

In addition to the factors covered by 3.4.2 to 3.4.12 there are certain aspects, applicable to particular occupancies only, which may effect the spread of fumes and thus the safe evacuation of the building in case of fire. Some such aspects are:

- a) interior finish and decoration;
- b) seating, aisles, railings, turnstiles and revolving doors in places of assembly;
- c) service equipment and storage facilities in buildings other than storage buildings; and
- d) hazards on stage, in waiting spaces, projection booths, etc, in theatres and cinemas.

3.4.15 Surface Interior Finishes

3.4.15.1 The use of combustible surface finishes on walls (including facade of the building) and ceilings affects the safety of the occupants of a building. Such finishes tend to spread the fire and even though the structural elements may be adequately fire resistant, serious danger to life may result. It is, therefore, essential to have adequate precautions to minimize spread of flame on wall, facade of building and ceiling surfaces.

The finishing materials used for various surfaces and décor shall be such that it shall not generate toxic smoke/fumes.

3.4.15.2 The susceptibility to fire of various types of wall surfaces is determined in terms of the rate of spread of flame. Based on the rate of spread of flame, surfacing material shall be considered as divided into four classes as follows (see also good practice [4(14)]).

Class 1 Surfaces of very low flame spread.

Class 2 Surfaces of low flame spread.

Class 3 Surfaces of medium flame spread.

Class 4 Surfaces of rapid flame spread.

3.4.15.3 The uses for which surface materials falling into various classes shall be adopted in building construction are given below:

Class 1	Class 2	Class 3
May be used in any situation	May be used in any situation, except on walls, facade of the building, staircase and corridors	May be used only in living rooms and bed rooms (but not in rooms on the roof) and only as a lining to solid walls and partitions; not on staircases or corridors or facade of the building.

NOTE — Panelling (lining) shall be permitted in a limited area. It shall not be permitted in a vestibule.

3.4.15.4 Materials of Class 4 which include untreated wood fibreboards may be used with due fire retardant treatment as ceiling lining, provided the ceiling is at least, 2.4 m from the top surface of the floor below, and the wall surfaces conform to requirements of class [see Note under 3.4.15.3] Class 4 materials shall not be used in kitchens, corridors and staircases. Some materials contain bitumen and, in addition to risk from spread of fire, emit dense smoke on burning; such materials shall be excluded from use under these conditions and shall also not be used for construction of ceiling where the plenum is used for return air in air-conditioned buildings [see also 5.1.7(m)].

3.4.15.5 When frames, walls, partitions or floors are lined with combustible materials, the surfaces on both sides of the materials shall conform to the appropriate class, because there is considerable danger from fire starting and rapidly spreading within the concealed cavity unknown to the occupants whose escape may be hampered there by. For detailed information on materials and details of construction with their fire-resistance rating, reference may be made to good practice [4(15)].

3.4.16 Glazing

3.4.16.1 Building of Types 1 to 4 construction shall employ one of the two types of glazing described in 3.4.16.2 and 3.4.16.3 except that Type 4 construction may have the alternative of hardwood sashes or frames or both.

3.4.16.2 Wired glass shall comply with the following requirements:

- a) *Wired glass* — The wired glass shall be of minimum half hour fire resistance rating.
- b) *Sashes and frames* — The sashes or frames or both shall be entirely of iron or other suitable metal such as stainless steel, securely bolted or keyed into the wall, except in the case of panels in internal doors.
- c) *Setting of glass* — The panels of glass shall be set in rebates or grooves not less than 6.0 mm in width or depth, with due allowance for expansion, and shall be secured by hard metal fastenings to the sashes or frames independently of any cement or putty used for weather-proofing purposes.

3.4.16.3 Electro-copper glazing shall comply with the following requirements:

- a) *Electro-copper glazing* — The electro-copper glazing shall be of minimum half hour fire resistance rating.
- b) *Sashes and frames* — The sashes or frames or both shall be entirely of iron or other hard metal, securely bolted or keyed into the wall, except when in panels in internal doors.
- c) *Fixing of sectional lights* — The sectional lights shall be set in rebate or grooves not less than 6.5 mm in width or depth, with due allowance for expansion and shall be secured by hard metal fastenings to the sashes or frames independently of any lead, cement or putty used for weather-proofing purposes.

3.4.16.4 Maximum permissible area shall be 5 m² for protection by wired glass or electro-copper glazing.

3.4.16.5 Casement

Hard metal casements, not exceeding 0.8 m² fitted with wired glass or electro-copper glazing in accordance with 3.4.16.2 and 3.4.16.3, secured to the frames by hard metal hinges not more than 600 mm apart and by fastening at top, centre and bottom shall be permissible.

3.4.17 Skylights

3.4.17.1 Wired glass for skylights or monitor lights shall comply with the following requirements:

- a) *Wired glass for skylights or monitor lights* — The wired glass for skylights or monitor lights shall be of minimum half hour fire resistance rating.
- b) *Frames and glazing* — The frame shall be continuous and divided by bars spaced at not more than 700 mm centres. The frame and bars shall be of iron or other hard metal, and supported on a curb either of metal or of wood covered with sheet metal. The toughened glass

shall be secured by hard metal fastenings to the frame and bars independently of any lead, cement or putty used for weather-proofing purposes.

3.4.18 Louvers

Louvers wherever provided shall be of minimum half hour fire resistance rating.

3.4.19 Glass of facade for high rise buildings, etc shall be of minimum 1 h fire resistance rating.

4 LIFE SAFETY

4.1 General

Every building shall be so constructed, equipped, maintained and operated as to avoid undue danger to the life and safety of the occupants from fire, smoke, fumes or panic during the time period necessary for escape.

4.2 General Exit Requirements

4.2.1 An exit may be a doorway, corridor, passageway(s) to an internal staircase, or external staircase, or to a VERANDAH or terrace(s), which have access to the street, or to the roof of a building or a refuge area. An exit may also include a horizontal exit leading to an adjoining building at the same level.

4.2.2 Lifts and escalators shall not be considered as exits.

4.2.3 Every exit, exit access or exit discharge shall be continuously maintained free of all obstructions or impediments to full use in the case of fire or other emergency.

4.2.4 Every building meant for human occupancy shall be provided with exits sufficient to permit safe escape of occupants, in case of fire or other emergency.

4.2.5 In every building or structure, exits shall comply with the minimum requirements of this part, except those not accessible for general public use.

4.2.6 No building shall be so altered as to reduce the number, width or protection of exits to less than that required.

4.2.7 Exits shall be clearly visible and the route to reach the exits shall be clearly marked and signs posted to guide the occupants of the floor concerned. Signs shall be illuminated and wired to an independent electrical circuit on an alternative source of supply. The sizes and colours of the exit signs shall be in accordance with good practice [4(16)]. The colour of the exit signs shall be green.

NOTE — This provision shall not apply to A-2 and A-4 occupancies less than 15 m in height.

4.2.8 The floors of areas covered for the means of exit shall be illuminated to values not less than 1 ft candle (10 lux) at floor level. In auditoriums, theatres, concert halls and such other places of assembly, the illumination of floor exit/access may be reduced during period of performances to values not less than 1/5 ft candle (2 lux).

4.2.9 Fire doors with 2 h fire resistance shall be provided at appropriate places along the escape route and particularly at the entrance to lift lobby and stair well where a 'funnel or flue effect' may be created, inducing an upward spread of fire to prevent spread of fire and smoke.

4.2.10 All exits shall provide continuous means of egress to the exterior of a building or to an exterior open space leading to a street.

4.2.11 Exits shall be so arranged that they may be reached without passing through another occupied unit.

4.3 Occupant Load

For determining the exits required, the number of persons within any floor area or the occupant load shall be based on the actual number of occupants, but in no case less than that specified in Table 20.

4.3.1 Mezzanine

The occupant load of a mezzanine floor discharging to a floor below shall be added to that floor occupancy and the capacity of the exits shall be designed for the total occupancy load thus established.

4.4 Capacities of Exits

4.4.1 The unit of exit width, used to measure the capacity of any exit, shall be 500 mm. A clear width of 250 mm shall be counted as an additional half unit. Clear widths less than 250 mm shall not be counted for exit width.

NOTE — The total occupants from a particular floor must evacuate within 2½ minutes for Type 1 construction, 1½ minutes for Type 2 construction and 1 minute for Type 3 construction. Size of the exit door/exitway shall be calculated accordingly keeping in view the travel distance as per Table 22.

4.4.2 Occupants per unit exit width shall be in accordance with Table 21.

4.4.3 Horizontal Exit Allowance

When horizontal exit is provided in buildings of mercantile, storage, industrial, business and assembly occupancies, the capacity per storey per unit width of exit of stairways in Table 21 may be increased by 50 percent and in buildings of institutional occupancy it may be increased by 100 percent.

Table 20 Occupant Load
(Clause 4.3)

Sl No.	Group of Occupancy	Occupant Load, Floor Area in m ² /Person
(1)	(2)	(3)
i)	Residential (A)	12.5
ii)	Educational (B)	4
iii)	Institutional (C)	15 (see Note 1)
iv)	Assembly (D)	
	a) With fixed or loose seats and dance floors	0.6 (see Note 2)
	b) Without seating facilities including dining rooms	1.5 (see Note 2)
v)	Mercantile (F)	
	a) Street floor and sales basement	3
	b) Upper sale floors	6
vi)	Business and industrial (E&G)	10
vii)	Storage (H)	30
viii)	Hazardous (J)	10

NOTES

1 Occupant load in dormitory portions of homes for the aged, orphanages, insane asylums, etc. where sleeping accommodation is provided, shall be calculated at not less than 7.5 m² gross floor area/person.

2 The gross floor area shall include, in addition to the main assembly room or space, any occupied connecting room or space in the same storey or in the storeys above or below, where entrance is common to such rooms and spaces and they are available for use by the occupants of the assembly place. No deductions shall be made in the gross area for corridors, closets or other sub-divisions; the area shall include all space serving the particular assembly occupancy.

Table 21 Occupants per Unit Exit Width
(Clauses 4.4.2, 4.4.3 and C-1.6.2)

Sl No.	Group of Occupancy	Number of Occupants		
		Stairways	Ramps	Doors
(1)	(2)	(3)	(4)	(5)
i)	Residential (A)	25	50	75
ii)	Educational (B)	25	50	75
iii)	Institutional (C)	25	50	75
iv)	Assembly (D)	40	50	60
v)	Business (E)	50	60	75
vi)	Mercantile (F)	50	60	75
vii)	Industrial (G)	50	60	75
viii)	Storage (H)	50	60	75
ix)	Hazardous (J)	25	30	40

4.5 Arrangement of Exits

4.5.1 Exits shall be so located that the travel distance on the floor shall not exceed the distance given in Table 22.

4.5.2 The travel distance to an exit from the dead end of a corridor shall not exceed half the distance specified

in Table 22, except in assembly and institutional occupancies in which case it shall not exceed 6 m.

4.5.3 Whenever more than one exit is required for any room space or floor of a building, exits shall be placed as remote from each other as possible and shall be arranged to provide direct access in separate directions from any point in the area served.

Table 22 Travel Distance for Occupancy and Type of Construction
(Clauses 4.4.1, 4.5.1 and 4.5.2)

Sl No.	Group of Occupancy	Maximum Travel Distance Construction	
		Types 1 & 2 m	Types 3 & 4 m
(1)	(2)	(3)	(4)
i)	Residential (A)	30.0	22.5
ii)	Educational (B)	30.0	22.5
iii)	Institutional (C)	30.0	22.5
iv)	Assembly (D)	30.0	30.0
v)	Business (E)	30.0	30.0
vi)	Mercantile (F)	30.0	30.0
vii)	Industrial (G)	45.0	"
viii)	Storage (H)	30.0	"
ix)	Hazardous (J)	22.5	"

NOTES

1 For fully sprinklered building, the travel distance may be increased by 50 percent of the values specified.

2 Ramps shall be protected with automatic sprinkler system and shall be counted as one of the means of escape.

" Construction of type 3 or 4 is not permitted.

4.6 Number of Exits

4.6.1 General

The general requirements of number of exits shall supplement the requirement of different occupancies in 6.1 to 6.9.

4.6.2 All buildings, which are 15 m in height or above, and all buildings used as educational, assembly, institutional, industrial, storage, and hazardous occupancies and mixed occupancies with any of the aforesaid occupancies, having area more than 500 m² on each floor shall have a minimum of two staircases. They shall be of enclosed type; at least one of them shall be on external walls of buildings and shall open directly to the exterior, interior open space or to an open place of safety. Further, the provision or otherwise of alternative staircases shall be subject to the requirements of travel distance being complied with.

4.7 Doorways

4.7.1 Every exit doorway shall open into an enclosed stairway or a horizontal exit of a corridor or passageway providing continuous and protected means of egress.

4.7.2 No exit doorway shall be less than 1 000 mm in width except assembly buildings where door width shall be not less than 2 000 mm. Doorways shall be not less than 2 000 mm in height.

4.7.3 Exit doorways shall open outwards, that is, away from the room, but shall not obstruct the travel along any exit. No door, when opened, shall reduce the required width of stairway or landing to less than 900 mm; overhead or sliding doors shall not be installed.

NOTE — In the case of buildings where there is a central corridor, the doors of rooms shall open inwards to permit smooth flow of traffic in the corridor.

4.7.4 Exit door shall not open immediately upon a flight of stairs; a landing equal to at least the width of the door shall be provided in the stairway at each doorway; the level of landing shall be the same as that of the floor which it serves.

4.7.5 Exit doorways shall be openable from the side which they serve without the use of a key.

4.7.6 Mirrors shall not be placed in exit ways or exit doors to avoid confusion regarding the direction of exit.

4.8 Corridors and Passageways

4.8.1 Exit corridors and passageways shall be of width not less than the aggregate required width of exit doorways leading from them in the direction of travel to the exterior.

4.8.2 Where stairways discharge through corridors and passageways, the height of corridors and passageways shall be not less than 2.4 m.

4.8.3 All means of exit including staircases lifts lobbies and corridors shall be adequately ventilated.

4.9 Internal Staircases

4.9.1 Internal stairs shall be constructed of non-combustible materials throughout.

4.9.2 Internal stairs shall be constructed as a self-contained unit with an external wall of the building constituting at least one of its sides and shall be completely enclosed.

4.9.3 A staircase shall not be arranged round a lift shaft.

4.9.4 Hollow combustible construction shall not be permitted.

4.9.5 No gas piping or electrical panels shall be allowed in the stairway. Ducting in stairway may be permitted if it is of 1 h fire resistance rating.

4.9.6 Notwithstanding the detailed provision for exits in accordance with 4.3, 4.4 and 4.5, the following minimum width shall be provided for staircases:

a) Residential buildings (dwellings)	1.0 m
b) Residential hotel buildings	1.5 m
c) Assembly buildings like auditorium, theatres and cinemas	2.0 m
d) Educational buildings up to 30 m in height	1.5 m
e) Institutional buildings like hospitals	2.0 m
f) All other buildings	1.5 m

4.9.7 The minimum width of tread without nosing shall be 250 mm for internal staircase of residential buildings. This shall be 300 mm for assembly, hotels, educational, institutional, business and other buildings. The treads shall be constructed and maintained in a manner to prevent slipping.

4.9.8 The maximum height of riser shall be 190 mm for residential buildings and 150 mm for other buildings and the number shall be limited to 15 per flight.

4.9.9 Handrails shall be provided at a height of 1 000 mm to be measured from the base of the middle of the treads to the top of the handrails. Balusters/railing shall be provided such that the width of staircase does not reduce (see Fig. 1).

4.9.10 The number of people in between floor landings in staircase shall not be less than the population on each floor for the purpose of design of staircase. The design of staircase shall also take into account the following:

- The minimum headroom in a passage under the landing of a staircase and under the staircase shall be 2.2 m.
- For building 15 m in height or more, access to main staircase shall be through a fire/smoke check door of a minimum 2 h fire resistance rating. Fire resistance rating may be reduced to 1 h for residential buildings (except hotels and starred hotels).
- No living space, store or other fire risk shall open directly into the staircase or staircases.
- External exit door of staircase enclosure at ground level shall open directly to the open spaces or through a large lobby, if necessary.
- The main and external staircases shall be continuous from ground floor to the terrace level.
- No electrical shafts/AC ducts or gas pipes, etc, shall pass through or open in the staircases. Lifts shall not open in staircase.
- No combustible material shall be used for decoration/wall paneling in the staircase.
- Beams/columns and other building features shall not reduce the head room/width of the staircase.

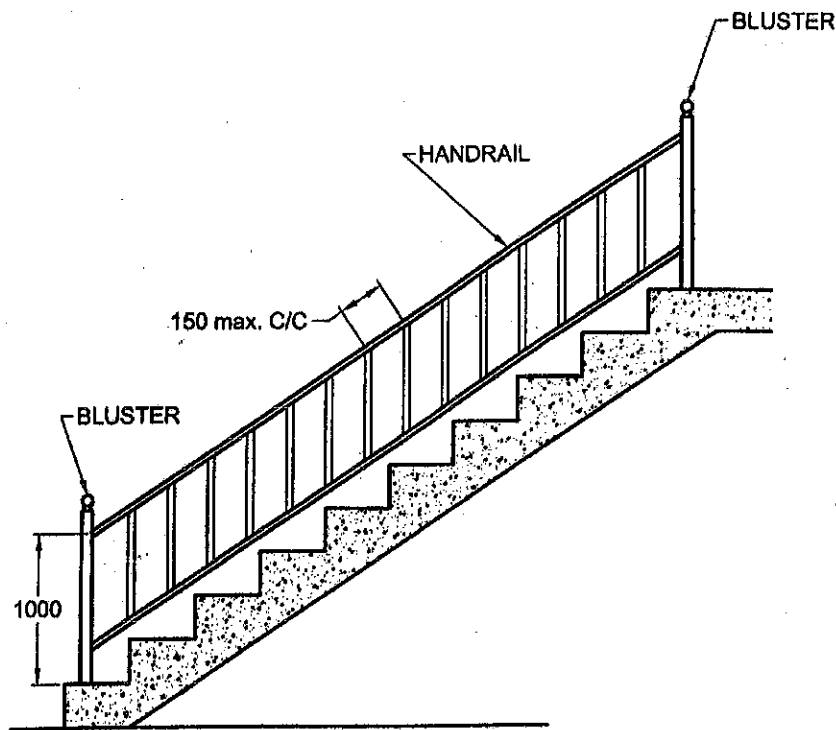

All dimensions in millimetres.

FIG. 1 TYPICAL DETAIL FOR HANDRAIL/BLUSTERS OF A STAIRCASE

- j) The exit sign with arrow indicating the way to the escape route shall be provided at a suitable height from the floor level on the wall and shall be illuminated by electric light connected to corridor circuits. All exit way marking signs should be flush with the wall and so designed that no mechanical damage shall occur to them due to moving of furniture or other heavy equipments. Further, all landings of floor shall have floor indicating boards prominently indicating the number of floor as per bye-laws.

The floor indication board shall be placed on the wall immediately facing the flight of stairs and nearest to the landing. It shall be of size not less than 0.5 m × 0.5 m.

- k) Individual floors shall be prominently indicated on the wall facing the staircases.
- m) In case of single staircase it shall terminate at the ground floor level and the access to the basement shall be by a separate staircase. The second staircase may lead to basement levels provided the same is separate at ground level by ventilated lobby with discharge points to two different ends through enclosures.

4.10 Pressurization of Staircases (Protected Escape Routes)

4.10.1 Though in normal building design, compartmentation plays a vital part in limiting the spread of fire, smoke will readily spread to adjacent spaces through the various leakage openings in the compartment enclosure, such as cracks, openings around pipes ducts, airflow grills and doors, as perfect sealing of all these openings is not possible. It is smoke and toxic gases, rather than flame, that will initially obstruct the free movement of occupants of the building through the means of escape (escape routes). Hence the exclusion of smoke and toxic gases from the protected routes is of great importance.

4.10.2 Pressurization is a method adopted for protected escape routes against ingress of smoke, especially in high-rise buildings. In pressurization, air is injected into the staircases, lobbies or corridors, to raise their pressure slightly above the pressure in adjacent parts of the building. As a result, ingress of smoke or toxic gases into the escape routes will be prevented. The pressurization of staircases shall be adopted for high rise buildings and building having mixed occupancy/multiplexes having covered area more than 500 m².

4.10.3 The pressure difference for staircases shall be as under:

Building Height	Pressure Difference	
	Reduced Operation (Stage 1 of a 2-Stage System) (Pa)	Emergency Operation (Stage 2 of a 2-Stage System or Single Stage System) (Pa)
Less than 15 m	8	50
15 m or above	15	50

If possible, the same levels shall be used for lobbies and corridors, but levels slightly lower may be used for these spaces if desired. The difference in pressurization levels between staircase and lobbies (or corridors) shall not be greater than 5 Pa.

4.10.4 Pressurization system may be of two types:

- Single-stage, designed for operation only in the event of an emergency, and
- Two-stage, where normally a level of pressurization is maintained in the protected escape routes and an increased level of pressurization can be brought into operation in an emergency.

4.10.5 The normal air-conditioning system and the pressurization system shall be treated as an integral one, especially for a two-stage system. When the emergency pressurization is brought into action, the following changes in the normal air-conditioning system shall be effected:

- Any re-circulation of air shall be stopped and all exhaust air vented to atmosphere;
- Any air supply to the spaces/areas other than escape routes shall be stopped;
- The exhaust system may be continued provided:
 - the positions of the extraction grills permit a general air flow away from the protected escape route entry;
 - the construction of the ductwork and fans is such that, it will not be rendered inoperable by hot gases and smoke; and
 - there is no danger of spread of smoke to other floors by the path of the extraction system which can be ensured by keeping the extraction fans running.

4.10.6 The pressurization system can be interconnected with the automatic/manual fire alarm system for actuation.

4.10.7 It will be desirable to have all the staircases in a building pressurized, if pressurization system is to

be resorted to. The use of pressurized and naturally ventilated staircases in the same building may introduce difficulties and hence shall be avoided. Under no circumstances shall a pressurized staircase be connected by a corridor or lobby to an un-pressurized staircase. Wherever pressurized staircase is to be connected to un-pressurized area, the two areas shall be segregated.

4.11. External Stairs

An external staircase is desirable to be provided for high rise buildings.

External stairs, when provided shall comply the following:

4.11.1 External stairs shall always be kept in sound operable conditions.

4.11.2 All external stairs shall be directly connected to the ground.

4.11.3 Entrance to the external stairs shall be separate and remote from the internal staircase.

4.11.4 Care shall be taken to ensure that no wall opening or window opens on to or close to an external stairs.

4.11.5 The route to the external stairs shall be free of obstructions at all times.

4.11.6 The external stairs shall be constructed of non-combustible materials, and any doorway leading to it shall have the required fire resistance.

4.11.7 No external staircase, used as a fire escape, shall be inclined at an angle greater than 45° from the horizontal.

4.11.8 External stairs shall have straight flight not less than 1 250 mm wide with 250 mm treads and risers not more than 190 mm. The number of risers shall be limited to 15 per flight.

4.11.9 Handrails shall be of a height not less than 1 000 mm and not exceeding 1 200 mm. There shall be provisions of balusters with maximum gap of 150 mm.

4.11.10 The use of spiral staircase shall be limited to low occupant load and to a building not exceeding 9 m in height.

A spiral stair case shall be not less than 1 500 mm in diameter and shall be designed to give adequate headroom.

4.11.11 Unprotected steel frame staircase will not be accepted as means of escape. However, steel staircase in an enclosed fire rated compartment of 2 h will be accepted as means of escape.

4.12 Horizontal Exits

4.12.1 The width of horizontal exit shall be same as for the exit doorways.

4.12.2 A horizontal exit shall be equipped with at least one fire/smoke door of minimum 1 h fire resistance, of self-closing type. Further, it is required to have direct connectivity to the fire escape staircase for evacuation.

4.12.3 For buildings more than 24 m in height, refuge area of 15 m² or an area equivalent to 0.3 m² per person to accommodate the occupants of two consecutive floors, whichever is higher, shall be provided as under:

The refuge area shall be provided on the periphery of the floor or preferably on a cantilever projection and open to air at least on one side protected with suitable railings.

- a) For floors above 24 m and Up to 39 m — One refuge area on the floor immediately above 24 m.
- b) For floors above 39 m — One refuge area on the floor immediately above 39 m and so on after every 15 m. Refuge area provided in excess of the requirements shall be counted towards FAR.

NOTE — Residential flats in multi-storied building with balcony, need not be provided with refuge area, however flats without balcony shall provide refuge area as given above.

4.12.4 Where there is a difference in level between connected areas for horizontal exits, ramps, not more than 1 in 10 m slope shall be provided; steps shall not be used.

4.12.5 Doors in horizontal exits shall be openable at all times from both sides.

4.13 Fire Tower

Fire towers are the preferred type of escape route for storeyed buildings and these shall be considered as the safest route for escape. Their number, location and size shall depend on the building concerned, and its associated escape routes.

4.13.1 In high rise buildings with over 8 storeys or 24 m in height, at least one required means of egress shall preferably be a fire tower.

4.13.2 The fire towers shall be constructed of walls with a 2 h fire resistance rating without openings other than the exit doorways, with platforms, landings and balconies having the same fire-resistance rating.

4.14 Ramps

4.14.1 Ramps shall comply with all the applicable requirements for stairways regarding enclosure,

capacity and limiting dimensions except where specified in 6.1 to 6.9 for special uses and occupancies.

4.14.2 The slope of a ramp shall not exceed 1 in 10. In certain cases steeper slopes may be permitted but in no case greater than 1 in 8.

4.14.3 For all slopes exceeding 1 in 10 and wherever the use is such as to involve danger of slipping, the ramp shall be surfaced with approved non-slipping material.

4.15 Fire Lifts

4.15.1 Where applicable, fire lifts shall be provided with a minimum capacity for 8 passengers and fully automated with emergency switch on ground level. In general, buildings 15 m in height or above shall be provided with fire lifts.

4.15.2 In case of fire, only fireman shall operate the fire lift. In normal course, it may be used by other persons.

4.15.3 Each fire lift shall be equipped with suitable inter-communication equipment for communicating with the control room on the ground floor of the building.

4.15.4 The number and location of fire lifts in a building shall be decided after taking into consideration various factors like building population, floor area, compartmentation, etc.

4.16 Emergency and Escape Lighting

4.16.1 Emergency lighting shall be powered from a source independent of that supplying the normal lighting [see good practice {4(17)}].

Escape lighting shall be capable of:

- a) Indicating clearly and unambiguously the escape routes,
- b) Providing adequate illumination along such routes to allow safe movement of persons towards and through the exits,
- c) Ensuring that fire alarm call points and fire-fighting equipments provided along the escape routes can be readily located.

4.16.2 The horizontal luminance at floor level on the centreline of an escape route shall be not less than 10 lux. In addition, for escape routes up to 2 m wide, 50 percent of the route width shall be lit to a minimum of 5 lux.

4.16.3 The emergency lighting shall be provided to be put on within 1 s of the failure of the normal lighting supply.

4.16.4 Escape lighting luminaries should be sited to cover the following locations:

- a) Near each intersection of corridors,
- b) at each exit door,
- c) Near each change of direction in the escape route,
- d) Near each staircase so that each flight of stairs receives direct light,
- e) Near any other change of floor level,
- f) Outside each final exit and close to it,
- g) Near each fire alarm call point,
- h) Near fire-fighting equipment, and
- j) To illuminate exit and safety signs as required by the enforcing authority.

NOTE — For the purposes of this clause 'near' is normally considered to be within 2 m measured horizontally.

4.16.5 Emergency lighting systems shall be designed to ensure that a fault or failure in any one luminaire does not further reduce the effectiveness of the system.

4.16.6 The luminaires shall be mounted as low as possible, but at least 2 m above the floor level.

4.16.7 Signs are required at all exits, emergency exits and escape routes, which should comply with the graphic requirements of the relevant Indian Standards.

4.16.8 Emergency lighting luminaires and their fittings shall be of non-flammable type.

4.16.9 It is essential that the wiring and installation of the emergency lighting systems are of high quality so as to ensure their perfect serviceability at all times.

4.16.10 The emergency lighting system shall be capable of continuous operation for a minimum duration of 1 h and 30 m even for the smallest premises.

4.16.11 The emergency lighting system shall be well maintained by periodical inspections and tests so as to ensure their perfect serviceability at all times.

4.17 Illumination of Means of Exit

Staircase and corridor lights shall conform to the following:

- a) The staircase and corridor lighting shall be on separate circuits and shall be independently connected so that it could be operated by one switch installation on the ground floor easily accessible to fire fighting staff at any time irrespective of the position of the individual control of the light points, if any. It should be of miniature circuit breaker type of switch so as to avoid replacement of fuse in case of crisis;

- b) Staircase and corridor lighting shall also be connected to alternative supply. The alternative source of supply may be provided by battery continuously trickle charged from the electric mains; and
- c) Suitable arrangements shall be made by installing double throw switches to ensure that the lighting installed in the staircase and the corridor does not get connected to two sources of supply simultaneously. Double throw switch shall be installed in the service room for terminating the stand-by supply.

4.18 Fire Detection and Warning

In buildings of such size, arrangement or occupancy where a fire may not itself provide adequate warning to occupants, automatic fire detection and alarm facilities shall be provided, where necessary, to warn occupants early of the existence of fire, so that they may escape, and to facilitate the orderly conduct of fire exit drills.

4.18.1 The fire detection system shall be in accordance with accepted standards [4(18)]. Guidelines for selection of various types of fire detectors for different occupancies and their installation and maintenance shall be in accordance with [4(19)].

4.18.2 The requirements of fire detection and alarm systems are covered for each occupancy in Table 23 and under 6.1 to 6.9; attention is also drawn to such requirements in case of high rise buildings (15 m or more in height) as given in Annex C.

5 FIRE PROTECTION

5.1 Fire Extinguishers/Fixed Fire Fighting Installations

5.1.1 All buildings depending upon the occupancy use and height shall be protected by fire extinguishers, wet riser, down-comer, automatic sprinkler installation, high/medium velocity water spray, foam, gaseous or dry powder system in accordance with the provisions of 5.1.2 to 5.1.9.

5.1.2 These fire extinguishers/fixed installations shall be in accordance with accepted standards [4(20)]. The typical requirements of fire extinguishers/wet riser/down-comer installation and capacity of water storage tanks and fire pumps, etc shall be as specified in Table 23. The requirements regarding size of mains/risers shall be as given in Table 24. The typical arrangements of down-comer and wet riser installations are shown in Fig. 2 and Fig. 3. The wet riser shall be designed for zonal distribution ensuring that unduly high pressures are not developed in risers and hose-pipes.

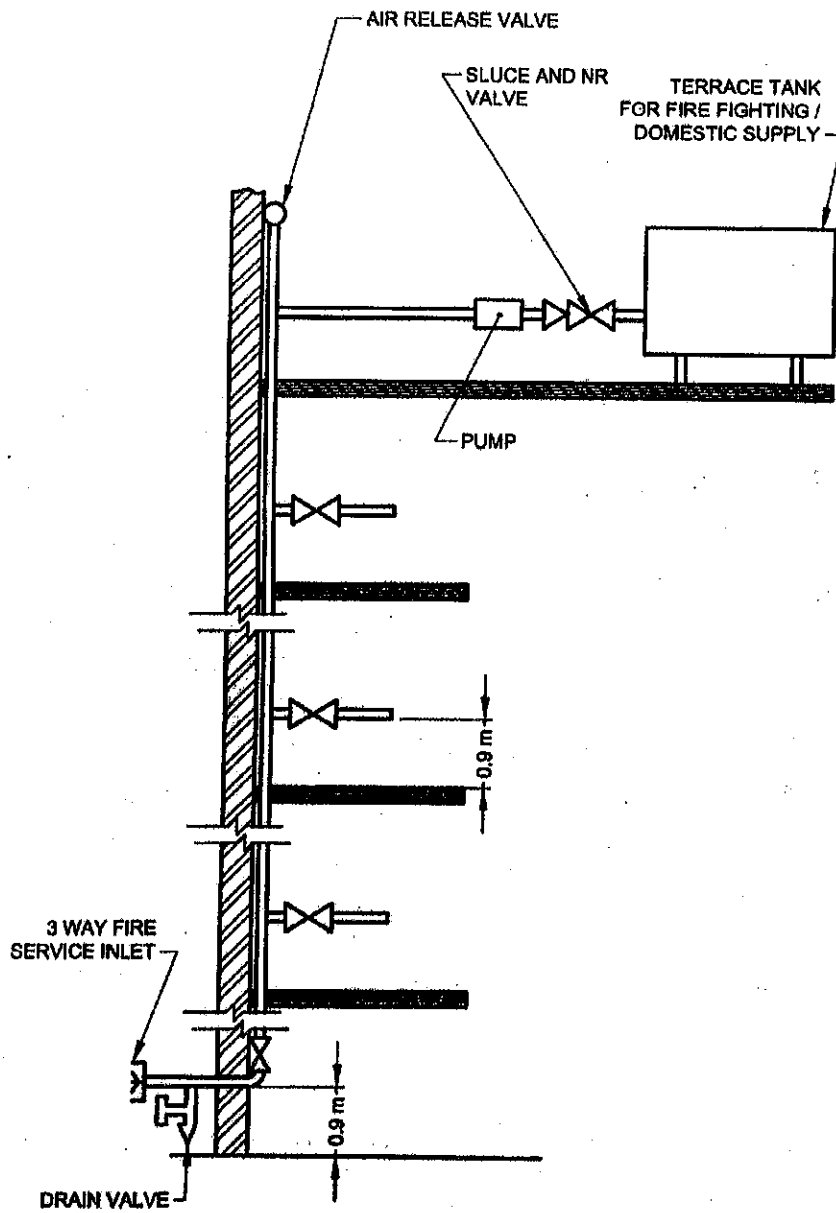

FIG. 2 TYPICAL ARRANGEMENT OF DOWN-COMER FOR BUILDING ABOVE 15 m BUT NOT EXCEEDING 30 m IN HEIGHT

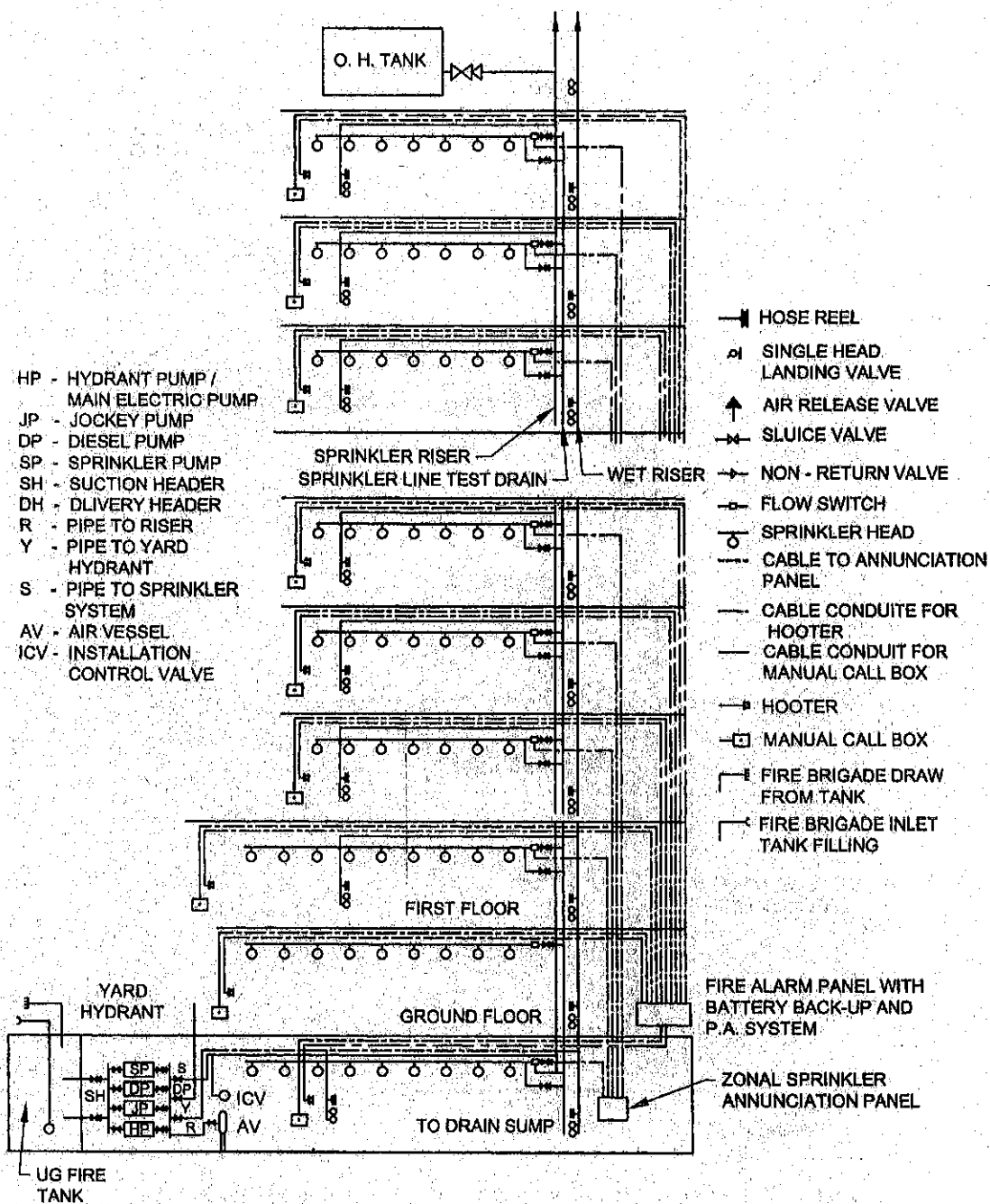

FIG. 3 TYPICAL ARRANGEMENT OF WET RISER AND TOTAL SPRINKLER SYSTEM OF BUILDING OTHER THAN APPARTMENT EXCEEDING 30 m IN HEIGHT

Table 23 Minimum Requirements for Fire Fighting Installations
(Clauses 4.18.2, 6.1.2, 6.2.3, 6.3.2, 6.4.3, 6.5.2, 6.5.2.1, 6.5.2.2, 6.5.2.3, 6.5.2.4, 6.5.2.5, 6.6.2, 6.7.2, 6.8.2 and 6.9.2)

SI No.	Type of Building Occupancy	Type of Installation										Water Supply (in l)		Pump Capacity (in l/min)	
		Fire Extinguisher	Hose Reel	Dry Riser (see Note 6)	Wet Riser	Down Corner	Yard Hydrant	Automatic Sprinkler System	Manually Operated Electric Fire Alarm Systems	Automatic Detection and Alarm System	Underground Static Water Storage Tank	Terrace Tank	Pump Near Underground Static Water Storage Tank (Fire Pump) with Minimum Pressure of 3.5 kg/cm ² at Terrace Level	At the Terrace Tank Level with Minimum Pressure of 2.0 kg/cm ²	
(1)	(2)	(3)	(4)	(5)	(6)	(7)	(8)	(9)	(10)	(11)	(12)	(13)	(14)	(15)	
RESIDENTIAL BUILDINGS (A)															
a) Lodging or Rooming Houses (A-1) (see Note 1)															
1) Less than 15 m in height															
i) Up to 15 rooms															
		R	NR	NR	NR	NR	NR	R (see Note 2)	NR	NR	NR	5 000 (see Note 3)	NR	NR	
ii) More than 15 and up to 30 rooms															
		R	R	NR	NR	NR	NR	R (see Note 2)	NR	NR	NR	5 000 (5 000) (see Note 4)	NR	450 (450) (see Note 4)	
iii) More than 30 rooms															
		R	R	NR	NR	NR	NR	R (see Note 2) (see Note 5)	R	NR	NR	10 000 (5 000) (see Note 4)	NR	450 (450) (see Note 4)	
b) One or two Family Private Dwellings (A-2) (see Note 1)															
		NR	NR	NR	NR	NR	NR	NR	NR	NR	NR	NR	NR	NR	

Table 23 — Continued

(1)	(2)	(3)	(4)	(5)	(6)	(7)	(8)	(9)	(10)	(11)	(12)	(13)	(14)	(15)
c) Dormitories (A-3) Apartment Houses (A-4)														
1)	Less than 15 m in height	R	R	NR	NR	NR	NR	R (see Note 2)	NR	NR	NR	5 000 (5 000) (see Note 4)	NR	450 (450) (see Note 4)
2)	15 m and above but not exceeding 35 m in height	R	R	NR	NR	R	NR	R (see Note 2)	R	NR	NR	25 000	NR	900
3)	Above 35 m but not exceeding 45 m in height	R	R	NR	R	NR	NR	R (see Notes 2 and 8)	R	NR	75 000	5 000 (5 000) (see Note 4)	(see Note 19)	NR
4)	Above 45 m in height but not exceeding 60 m in height	R	R	NR	R	NR	R	R	R	NR	75 000	10 000	(see Note 20)	NR
5)	Above 60 m in height	R	R	NR	R	NR	R	R	R	R	100 000	25 000	(see Note 21)	NR
d) Hotels (A-5)														
1)	Less than 15 m in height	R	R	NR	NR	NR	NR	R (see Note 2)	R	NR	NR	5 000 (see Note 2)	NR	450 (see Note 3)
i)	Covered area not exceeding 300 m ² on each floor	R	R	NR	NR	NR	NR	R (see Note 2)	R	NR	NR	10 000 for every 500 m ² covered area subject to minimum of 50 000 (see Note 5)	(see Notes 5 and 19)	NR
ii)	Covered area exceeding 300 m ² but not more than 1 000 m ² on each floor	R	R	NR	R	NR	NR	R (see Note 2)	R	R	100 000 (see Note 9)	10 000 (see Note 2)	(see Notes 9 and 19)	NR
iii)	Covered area exceeding 1 000 m ² on each floor	R	R	NR	R	NR	R	R (see Note 10)	R	R	100 000 (see Note 9)	10 000 (see Note 2)	(see Notes 9 and 19)	NR

Table 23 — Continued

(1)	(2)	(3)	(4)	(5)	(6)	(7)	(8)	(9)	(10)	(11)	(12)	(13)	(14)	(15)
2)	15 m and above but not exceeding 30 m	R	R	NR	R	NR	R	R	R	R	150 000	20 000	(see Note 20)	NR
3)	Above 30 m in height	R	R	NR	R	NR	R	R	R	R	200 000	20 000	(see Note 21)	NR
e)	Hotels (A-6)	R	R	NR	R	NR	R	R	R	R	200 000	20 000	(see Note 22)	NR
EDUCATIONAL BUILDINGS (B) (see Note 12)														
1)	Less than 15 m in height													
i)	Ground plus one storey	R	NR	NR	NR	NR	NR	R	NR	NR	NR	5 000 (see Note 3)	NR	450 (see Note 3)
ii)	Ground plus two or more storeys	R	R	NR	NR	NR	NR	R	NR	NR	NR	10 000 (5 000) (see Note 4)	NR	450 (450) (see Note 4)
2)	15 m and above but not exceeding 30 m in height	R	R	NR	NR	R	NR	R	R	NR	NR	25 000	NR	900
INSTITUTIONAL BUILDINGS (C) (see Note 12)														
a) Hospitals, Sanatoria and Nursing Homes (C-1)														
1)	Less than 15 m in height with plot area up to 1 000 m ²													
i)	Up to ground plus one storey, with no beds	R	R	NR	NR	NR	NR	R	R	NR	NR	2 500 (2 500) (see Note 4)	NR	NR
ii)	Up to ground plus one storey with beds	R	R	NR	NR	R	NR	R	R	NR	NR	5 000 (5 000) (see Note 4)	NR	450 (450) (see Note 4)
iii)	Ground plus two or more storeys, with no beds	R	R	NR	NR	R	NR	R	R	R	NR	5 000 (5 000) (see Note 4)	NR	450 (450) (see Note 4)
iv)	Ground plus two or more storeys, with beds	R	R	NR	R	NR	NR	R	R	R	50 000	5 000 (5 000) (see Note 4)	(see Note 19)	NR

Table 23 — Continued

(1)	(2)	(3)	(4)	(5)	(6)	(7)	(8)	(9)	(10)	(11)	(12)	(13)	(14)	(15)
2)	Less than 15 m in height with plot area more than 1 000 m ²	R	R	NR	R	NR	R	R	R	R	1 00 000	10 000	(see Note 19)	NR
3)	15 m and above but not exceeding 24 m in height	R	R	NR	R	NR	R	R	R	R	100 000	20 000	(see Note 20)	NR
4)	Above 24 m and not exceeding 30 m in height	R	R	NR	R	NR	R	R	R	R	1 50 000	20 000	(see Note 21)	NR
b) Custodial (C-2), and Penal and Pleural (C-3)														
1) Less than 10 m in height														
	i) Up to 300 persons	R	R	NR	NR	NR	NR	R	R	NR	NR	10 000 (5 000) (see Note 4)	NR	450 (900) (see Note 4)
	ii) More than 300 persons	R	R	NR	NR	R	NR	R	R	NR	NR	15 000 (5 000) (see Note 4)	NR	450 (900) (see Note 4)
2) 10 m and above but not exceeding 15 m in height														
	i) Up to 300 persons	R	R	NR	R	NR	R	R	R	R	50 000	5 000 (5 000) (see Note 4)	(see Note 20)	NR
	ii) More than 300 persons	R	R	NR	R	NR	R	R	R	R	75 000	10 000	(see Note 20)	NR
3) 15 m and above but not exceeding 24 m in height														
	i) Up to 300 persons	R	R	NR	R	NR	R	R	R	R	100 000	20 000	(see Note 21)	NR
	ii) More than 300 persons	R	R	NR	R	NR	R	R	R	R	100 000	20 000	(see Note 21)	NR
4) 24 m and above but not exceeding 30 m in height														
	i) Up to 300 persons	R	R	NR	R	NR	R	R	R	R	100 000	20 000	(see Note 21)	NR
	ii) More than 300 persons	R	R	NR	R	NR	R	R	R	R	100 000	20 000	(see Note 21)	NR
ASSEMBLY BUILDINGS (D) (see Note 12)														
a) Buildings (D-1 to D-5)														
1) Less than 10 m in height														
	i) Up to 300 persons	R	R	NR	NR	R	NR	R	R	NR	NR	10 000 (5 000) (see Note 4)	NR	450 (450) (see Note 4)
	ii) More than 300 persons	R	R	NR	NR	R	NR	R	R	NR	NR	10 000 (5 000) (see Note 4)	NR	450 (450) (see Note 4)

Table 23 — Continued

(1)	(2)	(3)	(4)	(5)	(6)	(7)	(8)	(9)	(10)	(11)	(12)	(13)	(14)	(15)
i)	More than 300 persons	R	R	NR	NR*	R	NR	R (see Note 2)	R	NR	NR	15 000 (5 000) (see Note 4)	NR	900
2)	Above 10 m but not exceeding 15 m in height	R	R	NR	R	NR	NR	R (see Note 2)	R	R	50 000	5 000 (5 000) (see Note 4)	(see Note 20)	450 (450) (see Note 4)
3)	Above 15 m but not exceeding 24 m in height	R	R	NR	R	NR	R	R (see Note 11)	R	R	75 000	10 000 (see Note 4)	(see Note 20)	NR
4)	Above 24 m but not exceeding 30 m in height	R	R	NR	R	NR	R	R (see Note 10)	R	R	100 000	20 000	(see Note 21)	NR
b)	Multiplex D-6	R	R	NR	R	NR	R	R (see Note 10)	R	R	200 000	20 000	(see Note 22)	NR
c)	D-7	For details see 6.4.3												
BUSINESS BUILDINGS (E)														
1)	Less than 10 m in height	R	R	NR	NR	R	NR	R (see Note 2)	R	NR	NR	10 000 (5 000) (see Note 4)	NR	450 (450) (see Note 4)
2)	Above 10 m but not exceeding 15 m in height	R	R	NR	R	NR	NR	R (see Note 2)	R	R	50 000	5 000 (5 000) (see Note 4)	(see Note 20)	450 (450) (see Note 4)
3)	Above 15 m and up to 24 m in height	R	R	NR	R	NR	R	R (see Note 11)	R	R	75 000	10 000	(see Note 20)	NR
4)	Above 24 m and up to 30 m in height	R	R	NR	R	NR	R	R (see Note 10)	R	R	100 000	20 000	(see Note 21)	NR
5)	Above 30 m in height	R	R	NR	R	NR	R	R (see Note 10)	R	R	200 000	20 000	(see Note 22)	NR
MERCANTILE BUILDINGS (F)														
a)	F-1 & F-2 (see Note 12)													
1)	Less than 15 m in height	R	R	NR	NR	R	NR	R (see Note 2)	NR	NR	NR	5 000 (5 000) (see Note 4)	NR	450 (450) (see Note 4)
i)	Ground plus one storey, with total covered area not exceeding 500 m ²	R	R	NR	NR	R	NR	R (see Note 2)	NR	NR	NR	5 000 (5 000) (see Note 4)	NR	450 (450) (see Note 4)

Table 23 — Continued

(1)	(2)	(3)	(4)	(5)	(6)	(7)	(8)	(9)	(10)	(11)	(12)	(13)	(14)	(15)
ii)	Ground plus one storey and covered area exceeding 500 m ²	R	R	NR	NR	R	NR	R (see Note 2)	R	NR	NR	25 000	NR	900
iii)	More than ground plus one storey	R	R	R	NR	R	NR	R (see Note 2)	R	NR	NR	5 000 (5 000) (see Note 4)	NR	900
2)	Above 15 m but not exceeding 24 m in height	R	R	NR	R	NR	NR	R (see Note 11)	R	R	100 000	10 000	(see Note 20)	NR
3)	Above 24 m but not exceeding 30 m in height	R	R	NR	R	NR	R	R (see Note 10)	R	R	150 000	10 000	(see Note 21)	NR
b)	Underground shopping complex (F-3) (see Note 13)	R	R	NR	R	NR	R	R (see Note 10)	R	R	150 000	10 000	(see Note 21)	NR
INDUSTRIAL BUILDINGS (G) (see Note 14)														
a) Low Hazard (G-1) (see Note 15)														
i)	Built up area up to 100 m ²	R	NR	NR	NR	NR	NR	R (see Note 2)	NR	NR	NR	5 000 (see Note 3)	NR	450 (see Note 3)
ii)	Built up area more than 100 m ² and up to 500 m ²	R	R	NR	NR	R	NR	R (see Note 2)	NR	NR	NR	5 000 (5 000) (see Note 4)	NR	450
iii)	Built up area more than 500 m ²	R	R	NR	R	R	R	R	NR	R	100 000	10 000	(see Note 20)	450
b) Moderate Hazard (G-2) (see Note 14)														
i)	Built up area up to 100 m ²	R	R	NR	NR	NR	NR	R	NR	NR	NR	10 000	NR	450
ii)	Built up area more than 100 m ² and up to 500 m ²	R	R	NR	NR	NR	NR	R	NR	NR	NR	10 000	NR	900

Table 23 — Continued

(1)	(2)	(3)	(4)	(5)	(6)	(7)	(8)	(9)	(10)	(11)	(12)	(13)	(14)	(15)
iii)	Built up area more than 500 m ² and up to 1 000 m ²	R	R	NR	R	R	R	R	R	R	75 000	20 000	(see Note 20)	900
iv)	Built up area more than 1 000 m ²	R	R	NR	R	R	R	R	R	R	100 000	20 000	(see Note 20)	900
c) High Hazard (G-3) (see Note 16)														
i)	Built up area up to 50 m ²	R	R	NR	NR	NR	NR	R	NR	NR	NR	5 000	NR	450
ii)	Built up area more than 50 m ² and up to 150 m ²	R	R	NR	NR	NR	NR	R	NR	R	NR	5 000	NR	450
iii)	Built up area more than 150 m ² and up to 300 m ²	R	R	NR	R	NR	NR	R	NR	R	25 000	10 000	(see Note 19)	450
iv)	Built up area more than 300 m ² and up to 500 m ²	R	R	NR	R	NR	R	R	R	R	50 000	20 000	(see Note 19)	900
v)	Built up area more than 500 m ²	R	R	NR	R	R	R	R	R	R	100 000	20 000	(see Note 20)	900
STORAGE BUILDINGS (H) (see Note 17)														
1)	Below 15 m in height and covered area less than 250 m ²	R	R	NR	NR	NR	NR	R	NR	NR	25 000	5 000	(see Note 19)	450
2)	Below 15 m in height and covered area more than 250 m ²													
i)	Ground floor only	R	R	NR	R	NR	R	R	NR	R	50 000	10 000	(see Note 20)	450
ii)	Ground plus one floor	R	R	NR	R	NR	R	R	NR	R	75 000	10 000	(see Note 20)	450

Table 23 — Concluded

(1)	(2)	(3)	(4)	(5)	(6)	(7)	(8)	(9)	(10)	(11)	(12)	(13)	(14)	(15)
iii)	More than ground plus one floor	R	R	NR	R	NR	R	R	NR	R	100 000	10 000	(see Note 20)	450
HAZARDOUS BUILDINGS (D) (see Note 17)														
1)	Up to 15 m in height													
i)	Single Storey Building	R	R	NR	NR	NR	R	R	R	R	Minimum 4 h fire fighting requirements	NR	(see Note 18)	NR
ii)	More than one floor building but not exceeding 15 m	R	R	NR	R	R	R	R	R	R	Minimum 4 h fire fighting requirements	50 000	(see Note 18)	900

R — Required
NR — Not Required

NOTES

- 1 Buildings above 15 m in height not to be permitted for occupancies A-1 and A-2.
- 2 Required to be installed in basement if area of basement exceeds 200 m².
- 3 Required to be provided if basement area exceeds 200 m².
- 4 Additional value given in parenthesis shall be added if basement area exceeds 200 m².
- 5 Required to be provided for buildings with more than two storeys (Ground + One).
- 6 As per the requirement of local authority Dry Riser may be used in hilly areas, industrial areas or as required.
- 7 Required to be provided for buildings with height above 15 m.
- 8 To be installed in basement. If basement provided, is used for car parking and area thereof exceeds 750 m² then the sprinklers shall be fed water from both underground static water storage tank and terrace tank.
- 9 Required to be provided for buildings with more than one storey.
- 10 To be installed in entire building.
- 11 To be installed in all floors at appropriate places and in consultation with local fire authorities.
- 12 Buildings above 30 m in height not to be permitted for Group B, Group C, Group D and Group F occupancies.
- 13 All underground shopping areas should be fully air-conditioned.
- 14 The requirements given in this table for Group G Industrial Buildings are for small scale industry units. For other industries the requirements will have to be worked out on the basis of relevant Indian Standards and also in consultation with the local fire authorities.
- 15 Buildings above 18 m in height not to be permitted for G-1 and G-2 occupancies.
- 16 Buildings above 15 m in height not to be permitted for G-3 occupancies.
- 17 Buildings above 15 m in height not to be permitted for Group H and Group J occupancies.

18. Pump capacity shall be based on the covered area of the building.
19. One electric and one diesel pump of capacity 1 620 l/min and one electric pump of capacity 180 l/min (see Fig. 4).
20. One electric and one diesel pump of capacity 2 280 l/min and one electric pump of capacity 180 l/min (see Fig. 4).
21. Two electric and one diesel pump of capacity 2 280 l/min and one electric pump of capacity 180 l/min (see Fig. 5).
22. Two electric and one diesel pump of capacity 2 850 l/min and one electric pump of capacity 180 l/min (see Fig. 5).
23. For buildings 45 m and above, the entire quantity of water for fire fighting purpose (as required in respective occupancy), if provided at the terrace level, the main pump sump/jockey pump and common pump need not be provided, however one electric fire pump of 900 LPM capacity with automatic operation is required to be provided.

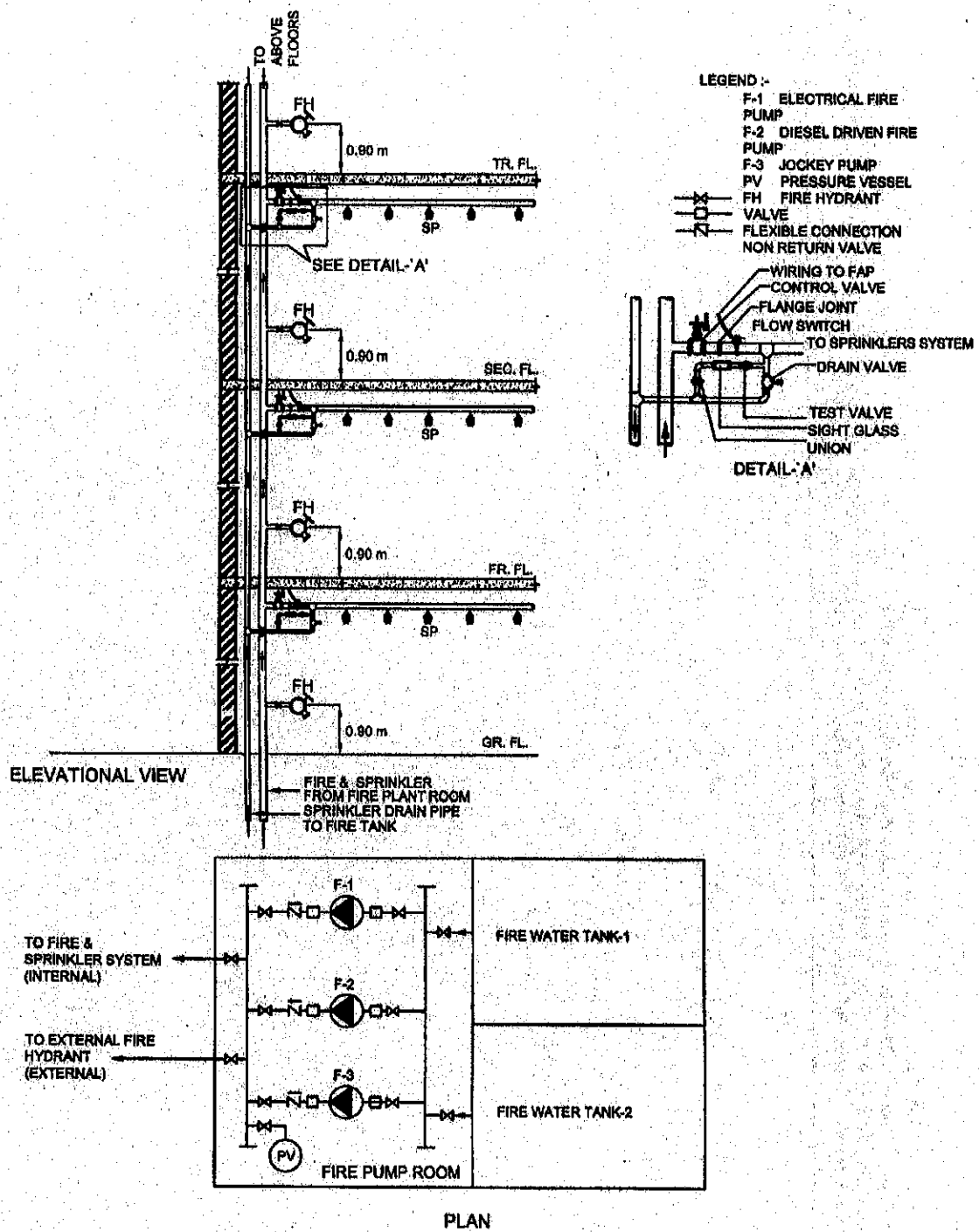

FIG. 4 TYPICAL SYSTEM OF PUMPING WITH ONE ELECTRIC AND ONE DIESEL FIRE PUMP

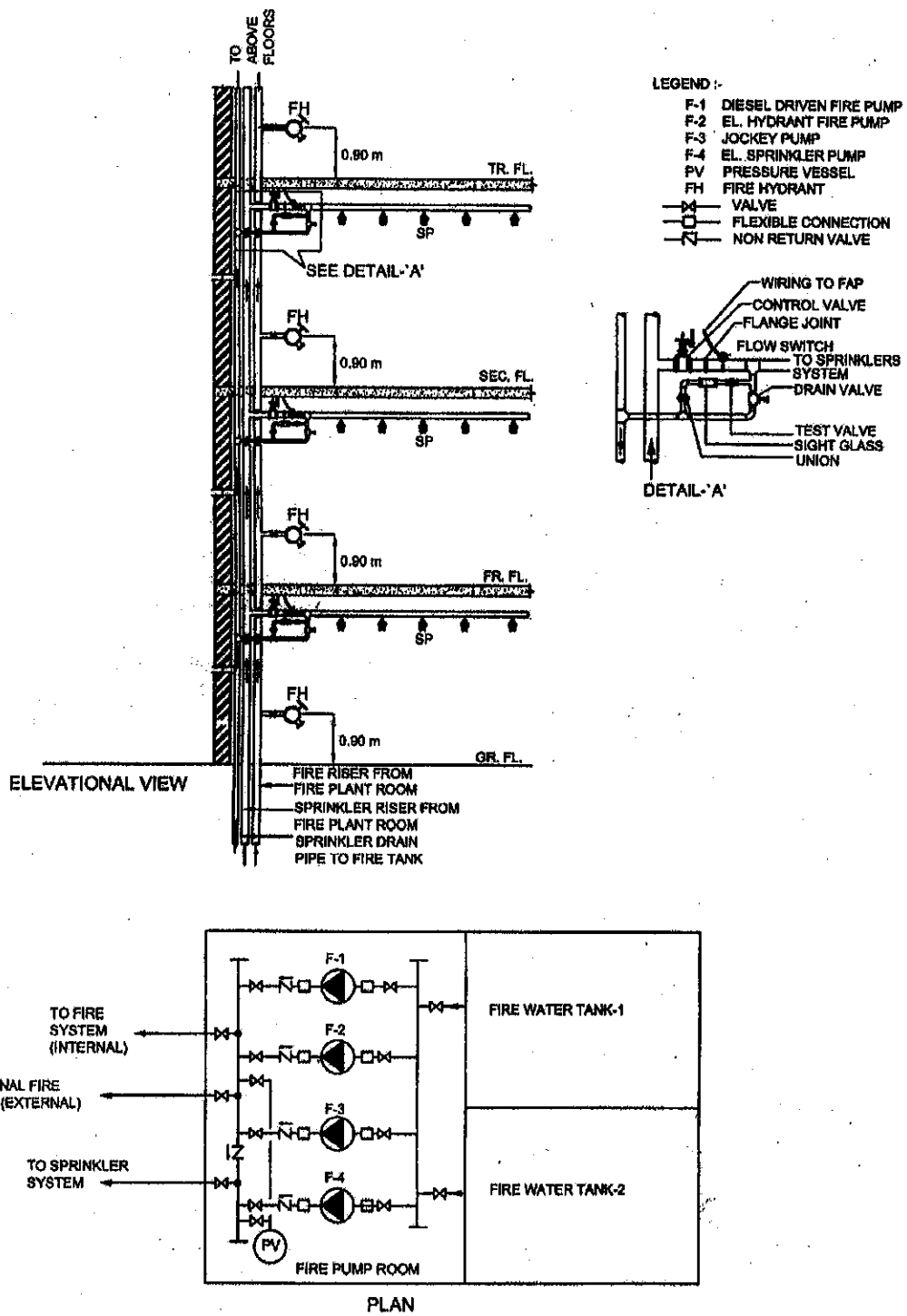

FIG. 5 TYPICAL SYSTEM OF PUMPING WITH TWO ELECTRIC, ONE DIESEL FIRE PUMP

5.1.3 In situations where one occupancy is provided with all the required fire protection arrangements but due to proximity of unprotected buildings around, causing exposure hazard to the protected building, the protected building walls facing the unprotected building shall be made of the requisite fire resistance rated materials or alternatively provided with water curtain/drencher system which can be actuated, when necessary.

5.1.4 First-aid fire fighting appliances shall be provided and installed in accordance with good practice [4(21)]. The fire fighting equipment and accessories to be installed in buildings for use in fire fighting shall be in accordance with the accepted standards contained in [4(20)] and shall be maintained periodically so as to ensure their perfect serviceability at all times.

5.1.5 In addition to wet riser or down-comer, first-aid hose reels shall be installed on all the floors of buildings of 15 m in height or more and shall be in accordance with accepted standards [4(22)]. The first-aid hose reel shall be connected directly to the riser/down-comer main and diameter of the hose reel shall not be less than 19 mm.

5.1.6 Static Water Storage Tanks

A satisfactory supply of water for the purpose of fire fighting shall always be available in the form of underground/terrace level static storage tank with capacity specified for each building with arrangements or replenishment by mains of alternative source of supply at the rate of 1 000 l/min for underground static tank. When this is not practicable, the capacity of static storage tank(s) shall be increased proportionately in consultation with the local fire brigade.

The static storage water supply required for the above mentioned purpose shall entirely be accessible to the fire engines of the local fire service. Provision of suitable number of manholes shall be made available for inspection, repairs, insertion of suction hose, etc. The covering slab shall be able to withstand the total vehicular load of 45 T equally divided as a four point load when the slab forms a part of pathway/driveway.

The domestic suction tank connected to the static water storage tank shall have an overflow capable of discharging 2 250 l/min to a visible drain point from which by a separate conduit, the overflow shall be conveyed to a storm water drain.

- a) To prevent stagnation of water in the static water storage tank, the suction tank of the domestic water supply shall be fed only through an overflow arrangement to maintain the level therein at the minimum specified capacity (*see Fig. 6*).

- b) The static water storage tank shall be provided with a fire brigade collecting head with 4 number 63 mm diameter (2 number 63 mm diameter for pump with capacity 1 400 l/min) instantaneous male inlets arranged in a valve box at a suitable point at street level and connected to the static tank by a suitable fixed pipe not less than 150 mm in diameter to discharge water into the tank when required at the rate of 2 250 l/min, if tank is in the basement or not approachable for the fire engines.

5.1.7 Automatic Sprinklers

Automatic sprinklers shall be installed in:

- a) basements used as car parks or storage occupancy, if the area exceeds 200 m²;
- b) multi-level basements, covered upper floors used as car parks, and for housing essential services ancillary to a particular occupancy or for storage occupancy, excluding any area to be used for sub-station, A.C. plant and DG set;
- c) any room or other compartment of a building exceeding 1 125 m² in area except as in (g) (*see Note 1*), if so advised by local authority;
- d) departmental stores or shops, if the aggregate covered area exceeds 500 m²;
- e) all non-domestic floors of mixed occupancy which constitute a hazard and are not provided with staircases independent of the remainder of the buildings;
- f) godowns and warehouses, as considered necessary;
- g) on all floors of the buildings other than residential and educational buildings, if the height of the building exceeds 15 m (45 m in case of group housing and apartments) (*see Note 1*);
- h) dressing room, scenery docks, stages and stage basements of theatres;
- j) in hotels, hospitals, industries low and moderate hazard mercantile buildings of height 15 m or above;
- k) in hotels below 15 m, if covered area at each floor is more than 1 000 m²;
- m) false ceiling voids exceeding 800 mm in height (*see Note 2*); and
- n) canteen provided in upper floors of D-1 and D-2 occupancies shall be sprinklered.

NOTES

1 It is desirable that all high rise buildings should be fully sprinklered irrespective of their height and occupancy. If

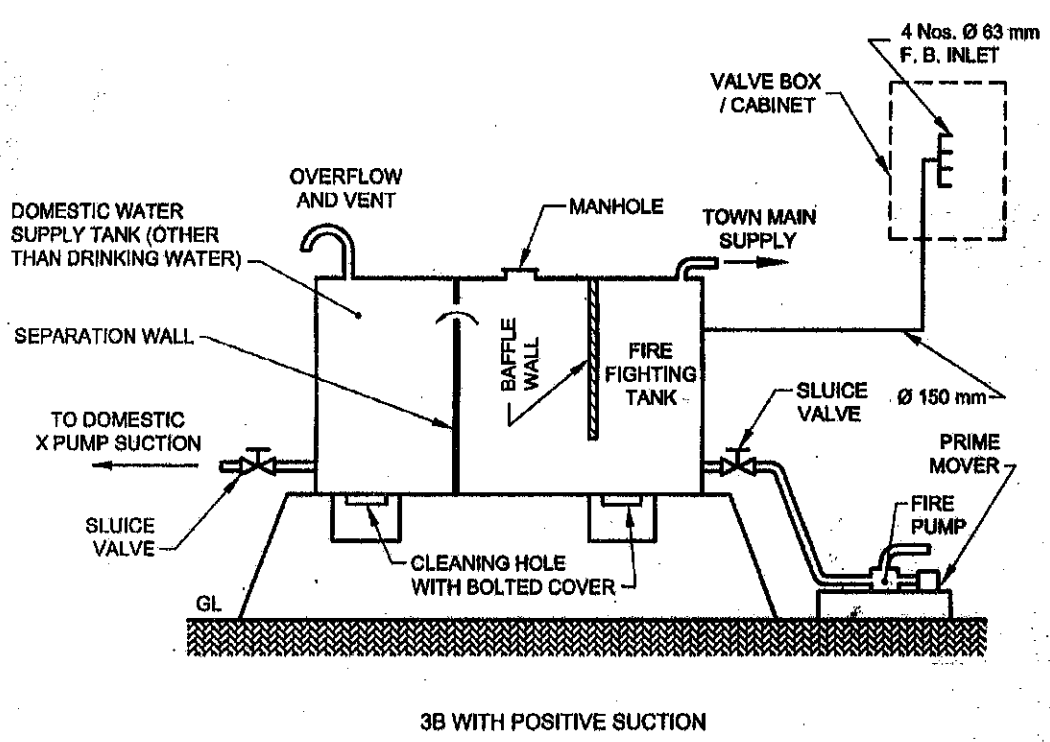
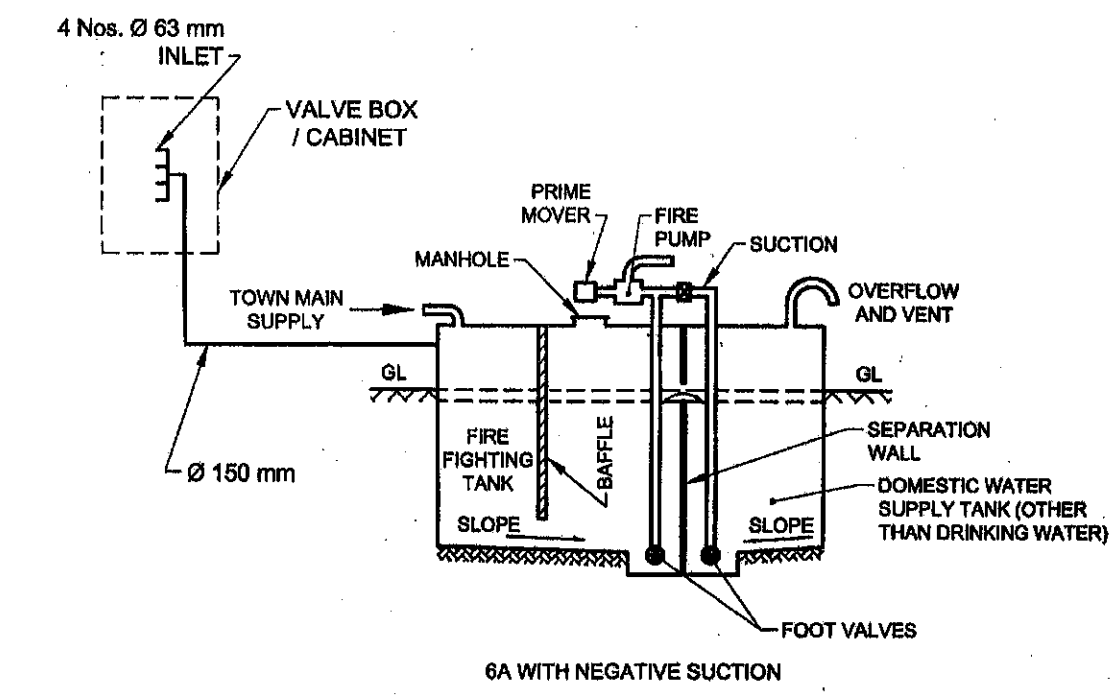

FIG. 6 TYPICAL ARRANGEMENT FOR PROVIDING COMBIND FIRE FIGHTING AND DOMESTIC WATER STORAGE TANK

Table 24 Size of Rising Mains/Risers
(Clause 5.1.2)

Size of the Mains (1)	Type of Building (2)	Height of Building (3)	
100 mm as single outlet landing valves	1. Residential buildings (A)		
	i) ¹⁾ Lodging or rooming houses		
	ii) Dormitories		
	iii) One or two family private dwellings	15 m or above and not exceeding 45 m	
	iv) Apartment houses (flats)		
	v) With shopping area not exceeding 500 m ²	Less than 15 m	
	vi) Hotels	15 m or above in height but not exceeding 30 m and area not exceeding 600 m ² per floor	
	-do-	2. Educational buildings (B)	15 m or above but not exceeding 30 m
	-do-	3. Institutional buildings (C)	
		i) For hospitals and sanatorium	15 m or above but not exceeding 30 m
		ii) For custodial institutions and mental institutions	15 m or above but not exceeding 30 m
	-do-	4. Assembly buildings (D)	15 m or above but not exceeding 30 m and total floor area not exceeding 500 m ² /floor (above 30 m, not to be permitted)
	-do-	5. Business buildings (E)	15 m or above but not exceeding 30 m
	-do-	6. Mercantile buildings (F)	15 m or above but not exceeding 30 m (above 30 m, not to be permitted)
	-do-	7. Industrial buildings (G)	15 m or above but not exceeding 18 m
-do-	8. All buildings classified under 1 (i) to (iv)	Above 45 m	
-do-	9. All buildings classified under 5 above with shopping area exceeding 500 m ²	Above 15 m	
-do-	10. All buildings classified under 1 (v) above	Above 30 m and area exceeding 500 m ²	
150 mm with twin outlet landing valves	11. Hotels	Above 30 m	
	-do-	12. All buildings classified under 2 and 3 above	Above 30 m
	-do-	13. All buildings classified under 5 above	Above 30 m
	-do-	14. All storage buildings (H)	Above 10 m but not exceeding 15 m
	-do-	15. All Hazardous buildings (J)	Above 10 m but not exceeding 15 m

¹⁾ Buildings above 15 m in height not permitted in case of high hazard industrial buildings.

selective sprinklering is adopted, there is a real danger of a fire starting on one of the lower unsprinklered floors gathering momentum, spreading upwards from floor to floor through the unsprinklered floor and reaching the first sprinklered floor as a fully developed fire. In such an event, the sprinklers can be rendered useless or ineffective.

2. Use of false ceiling voids for storage or as return air plenums should be discouraged.

3. For areas having very high ceiling height and other special function areas, where automatic sprinklers cannot be provided, appropriate sprinklers/provisions shall be provided in consultation with local fire authorities.

5.1.8 Automatic High Velocity Water Spray or Emulsifying System

Automatic high velocity water spray or emulsifying system shall be provided for protection of indoor oil-

cooled transformers as applicable in accordance with C-1.16 and good practice [4(23)].

5.1.9 Fixed Foam Installation

Fixed foam generating system shall be provided for protection of oil storage area for boilers with its ancillary storage of furnace oils in basement. Fixed foam installations can be low, medium or high expansion types, which can cover fire risks in oil storage areas generally. High expansion foams are used for cable tunnels and other confined areas.

5.1.10 Carbon Dioxide Fire Extinguishing System

Fixed carbon dioxide fire extinguishing installation shall be provided in accordance with good practice

[4(24)] on premises where water or foam cannot be used for fire extinguishing because of the special nature of the contents of the buildings/areas to be protected. For some special fire risk/essential applications, carbon dioxide may not be suitable and it may be necessary to provide BCF (Bromochlorodifluoromethane) — Halon 1211 or BTM (Bromochlorotrifluoromethane) — Halon 1301 or some other identified substitutes.

However, the use of halons shall be discouraged, as halons are ozone depleting substances (ODS) and their use is being phased out throughout the world.

5.1.11 Fire fighting equipment shall be suitably located and clearly marked by luminous signs.

NOTE — This provision shall not apply to occupancies A-2 and A-4 less than 15 m in height.

5.2 Fire Detection/Extinguishing System

In buildings of such size, arrangement or occupancy that a fire may not itself provide adequate warning to occupants, automatic fire detection and alarm facilities shall be provided, where necessary, to warn occupants early of the existence of fire, so that they may escape, or to facilitate the orderly conduct of fire exit drills.

5.2.1 The fire detection and extinguishing system shall be in accordance with accepted standards [4(18)]. Guidelines for selection of various types of fire detectors for different occupancies shall be in accordance with good practice [4(19)]. Addressable analog fire detection system shall be preferred.

5.2.2 The requirements of fire detection and alarm systems are also covered for each occupancy in 6.1 to 6.9; and for high rise buildings (15 m or more in height) in Annex C.

5.3 Fire Extinguisher/Extinguishing System Using Halon Alternatives

Provisions for certain fire extinguishers and extinguishing systems for fire protection which may be used as halon alternatives, shall be in accordance in [4(25)].

6 ADDITIONAL OCCUPANCY-WISE REQUIREMENTS

6.1 Requirements of Residential Buildings (Group A)

6.1.1 In addition to the general requirements for the type of construction and occupancy group specified in 3.4 and the exit requirements given in 4, the requirements 6.1.2 to 6.1.4.10 shall be complied with. The capacity of any open mezzanine or balcony shall be added to the capacity of the floor below for the purpose of determining exit capacity.

6.1.2 Fire Detection/Extinguishing System

The requirements for occupancy sub-divisions A-1 to

A-5 as specified in Table 23 and Annex C (for High Rise Buildings) shall apply.

6.1.3 Exit Facilities

The capacity of any open mezzanine or balcony shall be added to the capacity of the floor for the purpose of determining the exit capacity.

6.1.3.1 In addition to requirements specified for occupancy sub-division A-2, the following shall be provided for occupancy sub-division A-1:

Every sleeping room above the street floor shall have access to two separate means of exits, at least one of which shall consist of an enclosed interior stairway, or a fire escape or horizontal exit all so arranged as to provide a safe path of travel to the outside of the building without traversing any corridor or space exposed to an unprotected vertical opening.

6.1.3.2 For occupancy sub-division A-2 of more than two rooms, every occupied room, excluding areas used solely for storage shall have at least two means of exits, at least one of which shall be a door or a stairway providing a means of un-obstructed travel to the outside of the building or street or grade level. No room or space shall be occupied which is accessible only by a ladder, folding stairs or through a trap door.

Further the following provisions shall be made:

All locking devices, which would impede or prohibit exit, such as chain type bolts, limited opening sliding type locks and burglar locks, which are not dis-engaged easily by quick-releasing catches, shall be prohibited. All closet door latches shall be such that even children can open the doors from inside. All bathroom door locks or fasteners shall be designed to permit the opening of the locked or closed door from the outside in an emergency without the use of a special key.

6.1.3.3 For occupancy sub-division A-3, the following provisions shall apply:

All dormitories shall have exits so arranged that from any sleeping room or open dormitory sleeping area, there shall be access to two separate and distinct exits in different directions with no common path of travel unless the room or space is subject to occupancy by not more than 10 persons and has a door opening directly to the outside of the building at street or grade level, or to an outside stairway in which case one means of exit may be accepted.

6.1.3.4 For occupancy sub-division A-4, the following provisions shall apply:

- a) Every individual living unit covered by occupancy sub-division A-4 shall comply with the requirement for occupancy sub-division A-2 in respect of exits.
- b) Every living unit shall have access to at least two separate exits, which are remote from each other and are reached by travel in different directions, except that a common path of travel may be permitted for the first 6 m (that is a dead end corridor up to 6 m long may be permitted) provided that single exit may be permitted under any of the conditions given under (c).
- c) Any part of building lower than the grade level shall have direct accessibility from outside.
- d) At least half of required exits shall discharge direct to the outside of the buildings; any other exit shall be the same as required for hotels.

6.1.3.5 For occupancy sub-divisions A-5 and A-6, the following provisions shall apply:

- a) Not less than two exits, as remote from each other as practicable, shall be accessible from every floor, including basements occupied for hotel purpose, except as a single exit as permitted in (b) below. Exits and ways of access thereto shall be so arranged that they are accessible in at least two different directions from every point in any open area, or from any room door.
- b) Any room or section with an outside door at street or grade level may have such outside door as a single exit, provided no part of the room or area is more than 15 m from the door measured along the natural path of travel.
- c) Provision of panic bars shall be provided in the exits.

6.1.3.5.1 Where stairways or other exits serve two or more upper floors, the same stairway or other exit required to serve any one upper floor may also serve other upper floors, except that no inside open stairway or ramp may serve as a required egress facility from more than one floor [see good practice 4(26)].

6.1.3.6 Basement Exits

- a) Basements occupied for hotel purposes shall have exits arranged in accordance with 6.1.3.5.
- b) Basement exits shall be sufficient to provide for the capacity of the basement as determined in accordance with 6.1.1. In no case shall there be less than two independent basement exits.
- c) Basement or sub-basements not open to the public and used only for heating equipment,

storage and service operations (other than kitchens, which are considered part of the hotel occupancy) shall have exits appropriate to the actual occupancy, in accordance with other applicable provisions of the Code, or in case of mixed occupancy where there may be doubt as to which other section is applicable, such basements shall have exits determined on the basis of lesser exit capacity.

6.1.4 Additional Precautions

6.1.4.1 Flammable liquids for household purposes shall be kept in tightly stoppered or sealed containers. For the limits of quantities of flammable liquids to be allowed in various occupancies, reference may be made to appropriate regulations.

6.1.4.2 No stove or combustion heater shall be located directly under or immediately at the foot of stairs or otherwise so located as to block escape in case of malfunctioning of the stove or heater.

6.1.4.3 All kitchen exhaust fans, where provided, shall be fixed to an outside wall or to a duct of non-combustible material, which leads directly to the outside. The ducts must not pass through areas having combustible materials.

6.1.4.4 All wiring shall be done in accordance with Part 8 'Building Services, Section 2 Electrical Installations', good practice [4(10)] and National Electric Code.

6.1.4.5 Where television is installed, all outdoor antennae shall be properly grounded and protected from lightning (see Part 8 'Building Services, Section 2 Electrical Installations').

6.1.4.6 Doors leading to rooms in which flammable liquids are stored or used shall be as in 4.7. Such assembly shall be self-closing and shall be posted with a sign on each side of the door in 25 mm high block letters stating — 'FIREDOOR — KEEP CLOSED'.

6.1.4.7 Where a boiler room is provided or a central heating plant is installed, which uses solid or liquid fuel, it shall be separated from rest of the building by a separation wall with all openings protected as in 3.4.7 and 3.4.8.

6.1.4.8 Rooms containing high pressure boilers, refrigerating machinery, transformers or other service equipment subject to possible explosion shall not be located directly under or adjacent to exits. All such rooms shall be effectively cut off from other parts of the building and shall be provided with adequate vents to the outside air.

6.1.4.9 All rooms or areas of high hazard in additions to those herein before mentioned, shall be segregated

or shall be protected as may be directed by the enforcing Authority where, in the opinion of the enforcing Authority, fire, explosion or smoke there from is likely to interfere with safe egress from the building.

6.1.4.10 For detailed information regarding fire safety requirements for hazardous petroleum products, reference may be made to the *Petroleum Act, 1934* and the Rules thereof.

6.2 Requirements of Educational Buildings (Group B)

6.2.1 In addition to the general requirements specified in 3.4 for the type of construction and occupancy group and the exit requirements given in 4, the requirements given in 6.2.2 to 6.2.6.3 shall be complied with.

6.2.2 Buildings intended for educational occupancy shall not be used for any hazardous occupancy.

6.2.3 Fire Detection/Extinguishing System

The requirements for occupancy sub-divisions B-1 and B-2 as specified in Table 23 and Annex C (for High Rise Buildings) shall apply.

6.2.4 Exit Facilities

The capacity of any open mezzanine or balcony shall be added to the capacity of the floor for the purpose of determining the exit capacity.

In addition to the provisions in 4, the following shall be provided:

6.2.4.1 Exits, in accordance with 4 shall be so arranged that at least two separate exits are available in every floor area. Exits shall be as remote from each other as practicable and so arranged that there are no pockets or dead ends of appreciable size in which occupants may be trapped.

6.2.4.2 Every room with a capacity of over 45 persons in area shall have at least two doorways.

6.2.4.3 Exterior doors shall be operated by panic bars or some other panic hardware device, except that doors leading from classrooms directly to the outside may be equipped with the same type of lock as is used on classroom doors leading to corridor, with no provision whatsoever for locking against egress from the classroom.

6.2.5 Additional Precautions

6.2.5.1 Storage of volatile flammable liquids shall be prohibited and the handling of such liquids shall be restricted to science laboratories only.

6.2.5.2 Each building shall be provided with an approved outside gas shut-off valve conspicuously

marked. The detailed requirements regarding safe use of gas shall be as specified in Part 9 'Plumbing Services, Section 3 Gas Supply'.

6.2.5.3 All exterior openings in a boiler room or rooms containing central heating equipment, if located below opening in another storey or if less than 3 m from other doors or windows of the same building, shall be protected by a fire assembly as in 3.4.8. Such assemblies shall be fixed, automatic or self-closing. Provisions of 6.1.4.7 shall also apply to this group of occupancy.

6.2.6 Exception and Deviation

6.2.6.1 Gymnasiums, indoor stadiums and similar occupancies may have floors/running tracks of wood, cinder, synthetic or unprotected steel or iron.

6.2.6.2 In gymnasiums and in multi-purpose school rooms having an area not greater than 300 m², 25 mm nominal tight tongue-and-grooved or 20 mm plywood wall covering may be used in the inner side in lieu of fire-resistant plaster.

6.2.6.3 A building, which will have only the first floor and is accessible to not more than 20 pupils at any time, may be used for school purposes with the following exceptions:

- a) Exterior walls or parts of walls which are less than 900 mm from adjacent property lines shall have no openings therein.
- b) Classrooms may have only one exit not less than 900 mm wide.

6.3 Requirements of Institutional Buildings (Group C)

6.3.1 In addition to the general requirements specified in 3.4 for the type of construction and occupancy group and the exit requirements given in 4, the requirements given in 6.3.2 to 6.3.5 shall be complied with.

6.3.2 Fire Detection/Extinguishing System

The requirements for occupancy sub-divisions as specified in Table 23 and Annex C (for High Rise Buildings) shall apply.

6.3.3 Exit Facilities

In addition to the provisions of 4, the following requirements shall be complied with.

6.3.3.1 In buildings or sections occupied by bed-ridden patients where the floor area is over 280 m², facilities shall be provided to move patients in hospital beds to the other side of a smoke barrier from any part of such building or section not directly served by approved horizontal exits or exits from the first floor (floor 2) of a building to the outside.

6.3.3.2 Not less than two exits of one or more of the following types shall be provided for every floor, including basement, of every building or section:

- a) Doors leading directly outside the building;
- b) Stairways;
- c) Ramps;
- d) Horizontal exits; and
- e) Fire tower.

6.3.3.3 All required exits that serve as egress from hospital or infirmary sections shall be not less than 2 m in clear width including patient bedroom doors to permit transportation of patients on beds, litters, or mattresses. The minimum width of corridors serving patients bedrooms in buildings shall be 2 400 mm. For detailed information on recommendations for buildings and facilities for the physically handicapped, reference may be made to good practice [4(27)].

6.3.3.4 Elevators constitute a desirable supplementary facility, but are not counted as required exits. Patient lifts shall also be provided with enough room for transporting a stretcher trolley.

6.3.3.5 Any area exceeding 500 m² shall be divided into compartments by fire resistant walls.

6.3.3.6 Doors in fire resistant walls shall be so installed that these may normally be kept in open position, but will close automatically. Corridor door openings in smoke barriers shall be not less than 2 000 mm in width. Provision shall also be made for double swing single/double leaf type door.

6.3.3.7 Exits and other features for penal and mental institutions, and custodial institutions shall be the same as specified for hospitals, in so far as applicable. Reliable means shall be provided to permit the prompt release of inmates from any locked section in case of fire or other emergency.

6.3.3.8 Wherever any inmates are confined in any locked rooms or spaces, adequate guards or other personnel shall be continuously on duty or immediately available to provide for release of inmates or for such other action as may be indicated in case of fire or other emergency.

6.3.3.9 No building constructed in whole or in part of combustible materials shall be used to confine inmates in cells or sleeping quarters, unless automatic sprinkler protection is provided.

6.3.3.10 All buildings or sections of buildings in penal and mental institutions used for manufacturing, storage or office purposes shall have exits in accordance with the provisions of the Code for those occupancies.

6.3.4 Additional Precautions

6.3.4.1 No combustible material of any kind shall be

stored or used in any building or section thereof used for institutional occupancy, except as necessary to normal occupancy and use of the building.

6.3.4.2 Bare minimum quantities of flammable material such as chloroform, ethyl alcohol, spirit, etc shall be allowed to be stored and handled. The handling of such liquids shall not be permitted by un-authorized persons. Bulk storage of these items, will be governed by relevant rules and safe practices.

6.3.5 Exceptions and Deviations

It is recognized that in institutions or part of buildings housing various types of psychiatric patients; or used as penal and mental institutions, it is necessary to maintain locked doors and barred windows; and to such extent the necessary provision in other sections of the Code requiring the keeping of exits unlocked may be waived. It is also recognized that certain type of psychiatric patients are not capable of seeking safety without adequate guidance. In buildings where this situation prevails, reliable means for the rapid release of occupants shall be provided, such as remote control of locks, or by keying all locks to keys commonly used by attendants.

6.4 Requirements of Assembly Buildings (Group D)

6.4.1 In addition to the general requirements specified in 3.4 for type of construction and occupancy group and the exit requirements given in 4, the requirements given in 6.4.2 to 6.4.8.9 shall be complied with.

6.4.2 Mixed Occupancy

Places of assembly in buildings of other occupancy, such as ballrooms in hotels, restaurants in stores and assembly rooms in schools, shall be so located, separated or protected as to avoid any undue danger to the occupants of the place of assembly from a fire originating in the other occupancy or smoke therefrom.

6.4.3 Fire Detection/Extinguishing System

The requirements for occupancy sub-divisions D-1 to D-5 as specified in Table 23 and Annex C (for High Rise Buildings) shall apply.

NOTE — Canteens shall not be provided in basements. If provided in the upper floors, it shall be sprinklered.

6.4.4 Exit Facilities

6.4.4.1 Every place of assembly, every tier or balcony, and every individual room used as a place of assembly shall have exits sufficient to provide for the total capacity thereof as determined in accordance with 4. Door width for assembly buildings shall not be less than 2 000 mm.

- a) Every place of assembly of sub-division D-1

shall have at least four separate exits as remote from each other as practicable.

- b) Every place of assembly of sub-division D-2, shall have at least two separate exits as remote from each other as practicable and if of capacity over 600 at least three exits shall be provided with each exit not less than of 2 000 mm width.

6.4.4.2 Clear aisles not less than 1.2 m in width shall be formed at right angles to the line of seating in such number and manner that no seat shall be more than seven seats away from an aisle. Rows of seats opening on to an aisle at one end only shall have not more than seven seats. Under the conditions, where all these aisles do not directly meet the exit doors, cross-aisles shall be provided parallel to the line of seating so as to provide direct access to the exit, provided that not less than one cross aisle for every 10 rows shall be required. The width of cross-aisles shall be minimum of 1 m. Steps shall not be placed in aisles to overcome differences in levels, unless the gradient exceeds 1 in 10.

6.4.4.3 The fascia of boxes, balconies and galleries shall have substantial railings not less than 1 000 mm high above the floor. The railings at the end of aisles extending to the fascia shall be not less than 1 100 mm high for the width of the aisle or 1 200 mm high at the foot of steps.

6.4.4.4 Cross-aisles except where the backs of seats on the front of the aisle project 600 mm or more above the floor of the aisle shall be provided with railings not less than 900 mm high.

6.4.4.5 No turnstiles or other devices to restrict the movement of persons shall be installed in any place of assembly in such a manner as to interfere in any way with the required exit facilities.

6.4.4.6 In theatres and similar places of public assembly where persons are admitted to the building at a time when seats are not available for them and are allowed to wait in a lobby or similar space until seats are available, such use of lobby or similar space shall not encroach upon the required clear width of exits. Such waiting shall be restricted to areas separated from the required exit ways by substantial permanent partitions or fixed rigid railing not less than 105 cm high. Exits shall be provided for such waiting spaces on the basis of one person for each 0.3 m² of waiting space area. Such exits shall be in addition to the exits specified for the main auditorium area and shall conform in construction and arrangement to the general rules of exits given above.

6.4.4.7 No display or exhibit shall be so installed or operated as to interfere in any way with access to any required exit, or with any required exit sign.

All displays or exhibits of combustible material or construction and all booths and temporary construction in connection therewith shall be so limited in combustibility or protected as to avoid any undue hazard of fire which might endanger occupants before they have opportunity to use the available exits, as determined by the authority.

6.4.4.8 Places of assembly in buildings of other occupancy may use exits common to the place of assembly and the other occupancy, provided the assembly area and the other occupancy are considered separately, and each has exits sufficient to meet the requirements of the Code.

6.4.4.9 Exits shall be sufficient for simultaneous occupancy of both the places of assembly and other parts of the building, unless the Authority determines that the conditions are such that simultaneous occupancy will not occur.

6.4.4.10 For any place of assembly under sub-division D-1, at least half the required means of exits shall lead directly outdoors or through exit ways completely separated from exits serving other parts of the building.

6.4.4.11 For detailed information regarding cinema buildings, reference may be made to good practice [4(28)].

6.4.5 Lighting

No open flame lighting devices shall be used in any place of assembly, except in the following cases:

- a) Where necessary for ceremonial purposes, the enforcing Authority may permit open flame lighting under such restrictions as are necessary to avoid danger of ignition of combustible materials or injury to occupants.
- b) Candles may be used on restaurant tables if securely supported on non-combustible bases and so located as to avoid danger of ignition of combustible materials.
- c) Open flame devices may be used on stages where they are a necessary part of theatrical performance, provided adequate precautions, satisfactory to the Authority are taken to prevent ignition of combustible materials.

6.4.6 Additional Precautions

6.4.6.1 The decorations of places of assembly shall be of non-flammable materials. Fabrics and papers used for such purpose shall be treated with an effective flame-retardant material. Stage settings made of combustible materials shall likewise be treated with fire retardant materials of Class 1 flame spread.

6.4.6.2 Seats in places of public assembly, accommodating more than 300 persons, shall be

securely fastened to the floor, except as permitted in 6.4.6.3. All seats in balconies and galleries shall be securely fastened to the floor, except that in nailed-in enclosures, boxes with level floors and having not more than 14 seats, the seats need not be fastened.

6.4.6.3 Chairs not secured to the floor may be permitted in restaurants, night clubs and other occupancies where the fastening of seats to the floor may not be practicable, provided that in the area used for seating, excluding dance floor, stage, etc, there shall be not more than one seat for each 1.4 m² of floor area and adequate aisles to reach exits shall be maintained at all times.

6.4.6.3.1 Rows of seats between aisles shall have not more than 14 seats.

6.4.6.3.2 Rows of seats opening on to an aisle at one end only shall have not more than 7 seats.

6.4.6.3.3 Seats without dividing arms shall have their capacity determined by allowing 450 mm per person.

6.4.6.4 The spacing of rows of seats from back-to-back shall be neither less than 850 mm nor less than 700 mm plus the sum of the thickness of the back and inclination of the back. There shall be a space of not less than 350 mm between the back of one seat and the front of the seat immediately behind it as measured between plumb lines.

6.4.6.5 Rooms containing high pressure boilers, refrigerating machinery other than domestic refrigerator type, large transformers or other service equipments subject to possible explosion shall not be located directly under or adjacent to the required exits. All such rooms shall be effectively cut off from other parts of the building and provided with adequate vents to the outer air.

6.4.6.6 All rooms or areas used for storage of any combustible materials or equipment, or for painting, refinishing, repair or similar purposes shall be effectively cut off from assembly areas or protected with a standard system of automatic sprinklers. They shall be located away from staircases.

6.4.6.7 Every stage equipped with fly galleries, grid irons and rigging for movable theatre type scenery, shall have a system of automatic sprinklers over and under such stage areas or spaces and auxiliary spaces, such as dressing rooms, store rooms and workshops, and the proscenium opening shall be provided with a fire-resisting curtain, capable of withstanding a lateral pressure of 4 kN/m² over the entire area. The curtain shall have an emergency closing device capable of causing the curtain to close without the use of power and when so closed, it shall be reasonably tight against the passage of smoke.

6.4.6.8 The stage roof of every theatre using movable scenery or having a motion picture screen of highly combustible construction shall have a ventilator or ventilators in or above it, openable from the stage floor by hand and also opening by fusible links or some other approved automatic heat/smoke actuated device, to give a free opening equal to at least one-eighth the area of the floor of the stage.

6.4.6.9 The proscenium wall of every theatre using movable scenery or decorations shall have, exclusive of the proscenium opening, not more than two openings entering the stage, each not to exceed 2 m² and fitted with self-closing fire resistant doors.

6.4.6.10 Every place of assembly in which projection of motion pictures by light is made shall have the projection apparatus enclosed in a fire-resisting fixed booth in accordance with good practice [4(27)], except that such booth shall not be required where no nitrocellulose motion picture film is used.

6.4.6.11 Automatic smoke vents actuated by smoke detectors shall be installed above the auditorium or theatres, including motion picture houses, with vent area equal to not less than 3 percent of the floor area of the auditorium, including the sum of the floor areas of all balconies, galleries, boxes and tiers. It may be desirable to provide a large number of small vents rather than a small number of large vents.

6.4.7 Exception and Deviation

6.4.7.1 Where boilers or central heating plants using liquid or solid fuel are located at grade level, these shall be separated from the remainder of the building by a separating wall with openings protected as in 3.4.7 and 3.4.8.

6.4.7.2 Gymnasiums, indoor stadiums and similar occupancies may have floors/running tracks of wood, cinder, synthetic or un-protected steel or iron.

6.4.7.3 The underside of continuous steel deck grand stands when erected outdoors need not be fire-protected when occupied for public toilets.

6.4.8 Fire Protection and Fire Fighting System for Metro Stations

6.4.8.1 Wet riser system

Main and diesel fire pump of 1 800 l/min capacity to be provided to support 3 to 4 hydrants at a time. Jockey pump capacity shall be 180 l/min. Where it is possible to extend reliable DG supply to the fire pump room without routing through the station building, the provision of diesel pump can be dispensed with and instead, two electric pumps may be provided out of which at least one should have DG back-up. The jockey pump should also have DG back-up.

6.4.8.2 Internal hydrant

The internal hydrant is proposed to be provided with 2 number RRL hose pipes of 38 mm dia with 63 mm standard instantaneous coupling along with associated branch pipes and cabinet and a first aid hose reel of 25 mm dia, length 45 m and fitted with 6.5 mm nozzle.

Two internal hydrants are proposed to be provided on each platform in such a way so that most of the platform is covered by hose. However, in case of necessity, the hose pipes from other hose cabinets can be utilized for extending the length of fire hose pipe for fire fighting, if need be. At the concourse level minimum two hydrants will be provided. In station where the concourse is split into two halves at least one hydrant is to be provided in each half of the concourse. Further, in case the area is more than 2 000 m², an additional first aid hose-reel point shall be provided for every additional 1 000 m².

In addition, hydrants shall be provided in commercial areas also.

One hydrant shall be provided at entry of each station at ground floor for providing the coverage to the parking area.

6.4.8.3 Sprinklers

Sprinklers are required to be provided only in the commercial areas, if any, in the station. The commercial areas will be segregated from the station area through 2 h fire rated walls and doors. Additional sprinkler pumps are not required, as two pumps already provided for hydrant system will take care of the sprinkler flow requirements.

However, if such commercial areas in the premises of stations are in isolated building separate from the station building then the provision of sprinkler pump and water tank capacities shall be as per this Code. The water storage and pumps may however be common.

6.4.8.4 Detectors

Detectors are required to be provided only in areas where there are false ceiling and false floor and areas of equipment rooms. Wherever there are false ceiling, the detectors should be provided both above and below

false ceiling giving due consideration to depth of false ceiling/flooring. However, in concourse, the detectors below false ceiling may not be effective due to heights/cross ventilation and therefore may not be provided. In other areas, because of high heights and cross-ventilations, detectors will not be effective and hence therefore can be dispensed. A conventional detection system will suffice at a normal station.

6.4.8.5 Manual call box

Manual call box should be provided at a central place on each platform (near emergency plunger) and at least two on the concourse, on each sidewall. When the concourse is in two halves there should be one manual call box on each side.

6.4.8.6 Manual panel gas flooding

Electric panels should have provision of manual gas flooding. Alternatively panels can be provided with linear heat sensing tubes with CO₂ cylinder. This required to be provided only in main power panels, that is HT panel, main LT panel, main LT distribution board and essential power panels and other such major panels.

6.4.8.7 External area of the station

A 'two way/four way' fire brigade inlet to be provided at ground level on each rising main for hydrants/sprinkles.

The 'Draw Off Connection' shall be provided on the underground tank for fire brigade.

6.4.8.8 Water tank capacity

Capacity of fire tanks at stations without any commercial development (Beverage stall/ATM/Florist/Book stalls up to total 250 m² excluded) shall be 50 000 litres.

However, at stations having commercial development, the fire tank capacity shall be 100 000 litres.

6.4.8.9 Portable fire extinguishers

For the purpose of standardization, the following portable extinguishers are recommended:

- | | |
|---------------------------------------|----------|
| a) Water CO ₂ type | 9 litres |
| b) CO ₂ fire extinguishers | 4.5 kg |

They shall be provided in various areas as detailed hereunder:

<i>Sl No.</i>	<i>Item</i>	<i>Numbers and Location</i>
(1)	(2)	(3)
PLATFORM		
1.	Internal Hydrants	Two at each platform. The hydrants at two platforms may be staggered for maximum coverage.
2.	Manual call box	One on each platform preferably near emergency plunger.
3.	Portable Extinguishers	One set of Water CO ₂ and CO ₂ type on each platform at a central area.
CONCOURSE		
1.	Internal Hydrants	Two at each concourse. When concourse is in two parts then each part should have at least one hydrant.
2.	Additional first-aid reel point	Additional first-aid reel point for every additional 1 000 m ² , if the area is more than 2 000 m ² . Similarly, if the concourse is in two parts then additional first aid reel point for every additional 1 000 m ² , if the area of the part is more than 1 000 m ² .
3.	Manual call box	Two at each concourse. When concourse is in two parts then each part should have at least one.
4.	Portable Extinguishers	Two sets at each concourse. When concourse is in two parts then each part should have at least one set.
5.	Detectors	Above false ceiling where depth of false ceiling is greater than 800 mm. Required in commercial areas also.
EQUIPMENT ROOM AREAS		
1.	Internal Hydrants/first-aid reel point	The requirement shall get covered with platform/concourse. Additional first-aid reel point may be provided, if required.
2.	Manual call box	One at a central place. When the equipment rooms are in two/more parts then each part should have one.
3.	Portable Extinguishers	One set for each room.
4.	Detectors	Above and below false ceiling and below floor giving due consideration to depth of false ceiling/floor.
5.	Response Indicator	To be provided.
6.	Panel gas flooding	To be provided for HT panel, main LT panel, main LT distribution board and essential power panels and other such major panels.
EXTERNAL AREAS		
1.	Hydrants	One at ground floor at each entry to station near staircase/DG room.
2.	Two/four way fire brigade inlet	To be provided for each riser/sprinkler riser.
3.	Fire brigade Draw-off connection	To be provided on water tank.

6.5 Business Buildings (Group E)

6.5.1 In addition to the general requirements specified in 3.4 for type of construction and occupancy group and the exit requirements given in 4, the requirements given in 6.5.2 to 6.5.5 shall be complied with.

6.5.2 Fire Detection/Extinguishing System

The requirements for occupancy sub-divisions as specified in Table 23 and Annex C (for High Rise Buildings) shall apply.

6.5.2.1 Occupancy sub-division E-1 (except office buildings)

<i>Details of Occupancy</i>	<i>Fire Detection/Extinguishing System</i>
E-1	Automatic fire alarm system (good practice [4(17)] and [4(18)], and Table 23).

6.5.2.2 Occupancy sub-division E-2

<i>Details of Occupancy</i>	<i>Fire Detection/Extinguishing System</i>
a) Laboratory with delicate instruments	Fixed automatic CO ₂ fire extinguishing system or automatic fire alarm system (good practice [4(18)] and [4(19)], and Table 23)
b) Solvent storage and/or flammable liquid	Automatic foam installation or automatic CO ₂ fire extinguishing system

6.5.2.3 Occupancy sub-division E-3

<i>Details of Occupancy</i>	<i>Fire Detection/Extinguishing System</i>
a) Area of computer installations	Automatic fire alarm system (good practice [4(18)] and [4(19)], and Table 23) any suitable halon alternative fire extinguishing system (see 5.3) or any other suitable fire extinguishing installation (see also [4(29)]).
b) Space under false ceiling (floor)	Automatic fire alarm system (good practice [4(18)] and [4(19)], and Table 23)
c) Space above false ceiling and below false floor	Automatic fire alarm system (good practice [4(18)] and [4(19)], and Table 23)
d) Electrical switch board	Automatic fire alarm system (good practice [4(18)] and [4(19)], and Table 23) and CO ₂ fire extinguishing installation

6.5.2.4 Occupancy sub-division E-4

<i>Details of Occupancy</i>	<i>Fire Detection/Extinguishing System</i>
Telephone exchanges	Any suitable halon alternative fire extinguishing system (see 5.3) and/or automatic sprinkler system as per requirement (see also Table 23)

6.5.2.5 Occupancy sub-division E-5

<i>Details of Occupancy</i>	<i>Fire Detection/Extinguishing System</i>
Broadcasting stations	Automatic fire alarm system based on smoke detectors and sprinkler system (see also Table 23)

6.5.3 Exit Facilities

6.5.3.1 In the case of mezzanines or balconies open to the floor below, or other unprotected vertical openings between floors, the population of the mezzanine or other subsidiary floor for level shall be added to that of the main floor for the purpose of determining the required exits, provided, however, that in no case shall the total number of exit units be less than that required if all vertical openings were enclosed.

6.5.3.2 Not less than two exits shall be provided for every floor, including basements occupied for office purposes or uses incidental thereto.

6.5.4 Additional Requirements

6.5.4.1 The handling and use of gasoline, fuel oil and other flammable liquids shall not be permitted, unless such use and handling complies with the appropriate regulations.

6.5.4.2 Every boiler room or room containing a central heating plant using solid or liquid fuel shall be separated from the rest of the building by a separating wall. Every boiler room or room containing a central heating plant, which burns gas as a fuel shall be adequately separated from the rest of the building.

6.5.5 Exception and Deviation

6.5.5.1 Basements used only for storage, heating, any other service equipment shall conform to exit requirements for Group H occupancies in all respects.

6.6 Requirements of Mercantile Buildings (Group F)

6.6.1 In addition to the general requirements specified in 3.4 for type of construction and occupancy and the exit requirements given in 4, the requirements given in 6.6.1.1 to 6.6.5 shall be complied with.

6.6.1.1 Mixed occupancy

No dwelling unit shall have its sole means of exit through any mercantile occupancy in the same building except in the case of a single family unit where the family operates the store.

6.6.2 Fire Detection/Extinguishing System

The requirements for occupancy sub-divisions F-1 to F-3 as specified in Table 23 and Annex C (for High Rise Buildings) shall apply.

6.6.3 Exit Facilities

In addition to the provisions of 4, the following requirements shall be complied with.

6.6.3.1 In the case of mezzanines or balconies open to the floor below, or other un-protected vertical openings between floors, the population or area of the

mezzanine or other subsidiary floor level shall be added to that of the main floor for the purpose of determining the required exits, provided, however, that in no case shall the total number of exit units be less than that required if all vertical openings were enclosed.

6.6.3.2 At least two separate exits shall be accessible from every part of every floor, including basements; such exits shall be as remote from each other as practicable and so arranged as to be reached by different paths of travel in different directions, except that a common path of travel may be permitted for the first 15 m from any point.

6.6.4 Additional Precautions

6.6.4.1 Requirements specified in 6.5.4.1 shall be applicable to all Group F occupancies also.

6.6.4.2 Hazardous areas of mercantile occupancies shall be segregated or protected suitably.

6.6.4.3 In self-service stores, no check-out stand or associated railings or barriers shall obstruct exits or required aisles or approaches thereto.

6.6.4.4 Open-air mercantile operations, such as open-air markets, gasoline filling stations, roadside stands for the sale of a farm produce and other outdoor mercantile operations shall be so arranged and conducted as to maintain free and unobstructed ways of travel at all times to permit prompt escape from any point of danger in case of fire or other emergency, but no dead-ends in which persons might be trapped due to display stands, adjoining buildings, fences, vehicles or other obstructions.

6.6.4.5 If mercantile operations are conducted in roofed-over areas, these shall be treated as mercantile buildings, provided canopies over individual small stands to protect merchandise from the weather shall not be constructed to constitute buildings for the purpose of the Code.

6.6.5 Exception and Deviation

Any mercantile occupancy, where goods of a highly hazardous nature are pre-dominant, shall be considered under Group J occupancy for the purpose of the Code.

6.7 Requirements of Industrial Buildings (Group G)

6.7.1 In addition to the general requirements specified in 3.4 for the type of construction and occupancy group and the exit requirements given in 4, the requirements given in 6.7.2 to 6.7.5 shall be complied with.

6.7.2 Fire Detection/Extinguishing System

The requirements for occupancy sub-divisions G-1 to G-3 as specified in Table 23 and Annex C (for High Rise Buildings) shall apply.

6.7.3 Exit Facilities

In addition to the provisions of 4, the following requirements shall be complied with.

6.7.3.1 Not less than two exits shall be provided for every floor or section, including basements used for industrial purposes or uses incidental thereto.

6.7.3.2 In buildings used for aircraft assembly or other occupancy requiring undivided floor areas so large that the distances from points within the area to the nearest outside walls where exit doors could be provided are in excess of 45 m, requirements for distance to exits may be satisfied by providing stairs leading to exit tunnels or to overhead passageways. In cases where such arrangements are not practicable, the Authority may, by special ruling, permit other exit arrangements for one storey buildings with distances in excess of the maximum distances specified in 4, if completely automatic sprinkler protection is provided and if the heights of ceiling curtain boards and roof ventilation are such as to minimize the possibility that employees will be overtaken by the spread of fire or smoke within 1 800 mm of the floor level before they have time to reach exits, provided, however, that in no case may the distance of travel to reach the nearest exit exceed 45 m where smoke venting is required as a condition for permitting distances of travel to exits in excess of the maximum otherwise allowed.

6.7.3.3 Additional precautions

- a) In any room in which volatile flammable substances are used or stored, no device generating a glow or flame capable of igniting flammable vapour shall be installed or used. Such a room shall be provided with a suitably designed exhaust ventilation system (see Annex D). To ensure safety from fire due to short circuit, faulty electrical connection or some similar cause, proper care shall be taken in designing electrical installations in such room (see Part 8 'Building Services, Section 2 Electrical Installations').
- b) The storage, use and handling of gasoline, fuel oil and other flammable liquids shall not be permitted in any Group G occupancy unless it complies with regulations pertaining to *Petroleum Act, 1934* and Rules thereunder.
- c) Every boiler room or room below the first floor containing a heating plant shall be adequately separated from the rest of the buildings.
- d) For requirements regarding electrical generating and distribution stations, reference may be made to good practice [4(23)].

6.7.3.4 Exception and deviation

- a) Basements used only for storage, heating or other service equipment, and not subject to industrial occupancy, shall have exits in accordance with the requirements of Group H occupancies.
- b) The following exceptions shall apply to special purpose industrial occupancies:
 - 1) Exits need be provided only for the persons actually employed; spaces not subject to human occupancy because of the presence of machinery or equipment may be excluded from consideration.
 - 2) Where unprotected vertical openings are necessary to manufacturing operations, these may be permitted beyond the limits specified for industrial occupancy, provided every floor level has direct access to one or more enclosed stairways or other exits protected against obstruction by any fire in the open areas connected by the unprotected vertical openings or smoke therefrom.
 - 3) Industrial buildings of low and moderate hazard are permitted only up to 18 m height.
- c) The following exceptions shall apply to high hazard industrial occupancies:
 - 1) Exits shall be so located that it will not be necessary to travel more than 22.5 m from any point to reach the nearest exit.
 - 2) From every point in every floor area, there shall be at least two exits accessible in different directions; where floor areas are divided into rooms, there shall be at least two ways of escape from every room, however small, except toilet rooms, so located that the points of access thereto are out of or suitably shielded from areas of high hazard.
 - 3) In addition to types of exits for upper floors specified for Group G occupancies, slide escapes may be used as required exits for both new and existing buildings.
 - 4) All high hazard industrial occupancies shall have automatic sprinkler protection or such other protection as may be appropriate to the particular hazard, including explosion venting for any area subject to explosion hazard, designed to minimize danger to occupants in case of fire or other emergency before they have time to utilize exits to escape.

- 5) Industrial buildings of high hazard are permitted only up to 15 m height.

6.7.4 For detailed information on fire safety of certain individual (specific) industrial occupancies reference may be made to good practice [4(39)].

6.7.5 Fire protection considerations for venting industrial occupancies shall be as given in Annex D.

6.8 Requirements of Storage Buildings (Group H)

6.8.1 In addition to the general requirements specified in 3.4 for type of construction and occupancy group and the exit requirements given in 4, the requirements given in 6.8.2 to 6.8.5 shall be complied with.

6.8.2 Fire Detection/Extinguishing System

The requirements for occupancy group H, as specified in Table 23 and Annex C (for High Rise Building) shall apply.

NOTE — Automatic sprinklers are prohibited where water reactive materials are kept. Instead automatic fire alarm system coupled with suitable fire extinguishing systems shall be installed.

6.8.3 Exit Facilities

In addition to the provisions of 4, the following requirements shall also be complied with.

6.8.3.1 Every building or structure used for storage and every section thereof considered separately, shall have access to at least one exit so arranged and located as to provide a suitable means of escape for any person employed therein and in any room or space exceeding 1 400 m² gross area, or where more than 10 persons may be normally present, at least two separate means of exit shall be available, as remote from each other as practicable.

6.8.3.2 Every storage area shall have access to at least two means of exit, which can be readily opened. This shall not be subject to locking so long as any persons are inside and shall not depend on power operation.

6.8.3.3 The following special provisions shall apply to parking garages of closed or open type, above or below ground, but not to mechanical parking facilities where automobiles are moved into and out of storage mechanically which are not normally occupied by persons and thus require no exit facilities. Where repair operations are conducted, the exits shall comply with the requirements of Group G occupancies in addition to compliance with the following:

- a) Where both parking and repair operations are conducted in the same building, the entire building shall comply with the requirements for Group G occupancies, unless the parking

- and repair sections are effectively separated by separation walls.
- b) Every floor of every closed parking garage shall have access to at least two separate means of exit, so arranged that from any point in the garage the paths of travel to the two means of exit shall be in different directions, except that a common path of travel may be permitted for the first 15 m. from any point.
 - c) On the street floor, at least two separate exit doors shall be provided, except that any opening for the passage of automobiles may serve as a means of exit, provided no door or shutter is installed thereon. Street floor exits in closed garages shall be so arranged that no point in the area is more than 30 m from the nearest exit, or 45 m in the case of garages protected by automatic sprinklers, distance being measured along the natural path of travel.
 - d) On floors above the street, at least two means of exit shall be provided, one of which shall be an enclosed stairway. The other means of egress may be a second exit of any of the types, or in a ramp type garage with open ramps not subject to closure, the ramp may serve as the second means of exit.
 - e) Upper floor exits in closed garages shall be so arranged that no point in the area shall be more than 30 m from the nearest exit other than a ramp on the same floor level or 45 m in the case of garages protected by automatic sprinklers.
 - f) On floors below the street (either basement or outside underground garages) at least two exits shall be provided, not counting any automobile ramps, except that for garages extending only one floor level below the street, a ramp leading direct to the outside may constitute one required means of exit. In garages below street level, exits shall be so arranged that no part of the area shall be more than 30 m from the nearest stair exit.
 - g) If any gasoline pumps are located within any closed parking garage, exits shall be so located that travel away from the gasoline pump in any direction shall lead to an exit; with no dead-end in which occupants might be trapped by fire or explosion at any gasoline pump. Such exit shall lead to the outside on the building on the same level, or downstairs; no upward travel shall be permitted unless direct outside exits are available from that floor and any floor below (as in the case of a basement garage where

the grade is one storey or more lower at the rear than at the street).

6.8.3.4 Exits from aircraft hangers (storage or servicing areas) shall be provided at intervals of not more than 45 m on all exterior walls of aircraft hangers. There shall be a minimum of two exits serving each aircraft storage or servicing areas. Horizontal exits through interior fire walls shall be provided at intervals of not more than 30 m. 'Dwarf or 'smash' doors accommodating aircraft may be used to comply with these requirements. All doors designated as exits shall be kept unlocked in the direction of exit travel while the area is occupied.

6.8.3.5 Exits from mezzanine floors in aircraft storage or servicing areas shall be so arranged that the maximum travel to reach the nearest exits from any point on the mezzanine shall not exceed 22.5 m. Such exits shall lead directly to a properly enclosed stairwell discharging directly to the exterior or to a suitably cut-off area or to outside fire escape stairs.

6.8.3.6 The following special provisions shall apply to grain elevators:

- a) There shall be at least one stair tower from basement to first floor and from the first floor to the top floor of workhouse which is enclosed in a dust-tight non-combustible shaft.
- b) Non-combustible doors of self-closing type shall be provided at each floor landing.
- c) An exterior fire escape of the stair or basket ladder type shall be provided from the roof of the workshop to ground level or the roof of an adjoining annexe with access from all floors above the first.
- d) An exterior fire escape of either the stair or basket ladder type shall be provided from the roof of each storage annexe to ground level.

6.8.4 Additional Precautions

Requirements specified in 6.7.3.3 shall apply to Group H occupancies also.

6.8.5 Exceptions and Deviations

Every area used for the storage of hazardous commodities shall have an exit within 22.5 m of any point in the area where persons may be present or 35 m where automatic sprinkler protection is provided.

6.9 Requirements of Buildings for Hazardous Uses (Group J)

6.9.1 In addition to the general requirements specified in 3.4 for type of construction and occupancy group and the exit requirements given in 4, the requirements given in 6.9.2 to 6.9.4 shall be complied with.

6.9.2 Fire Detection/Extinguishing System

The requirements for occupancy Group J, as specified in Table 23 and Annex C (for High Rise Building) shall apply.

NOTE — Hazardous buildings shall have vapour detectors/explosion suppression systems/automatic sprinklers, besides hydrant system, wet risers and automatic fire alarm system depending on the type of fire hazard involved.

6.9.3 Exit Facilities

Requirements specified in 4 and 6.7.3.4 (c) shall apply to Group J occupancies also.

6.9.4 Additional Precautions

The following requirements shall apply to all Group J occupancies, as applicable:

- a) Each building where gas is employed for any purpose shall be provided with an approved outside gas shut-off valve conspicuously marked. The detailed requirements regarding safe use of gas shall be as specified in Part 9 'Plumbing Services, Section 2 Gas Supply'.
- b) Each boiler room or room containing a heating plant shall be separated from the rest of the building by a separating wall.
- c) In any room in which volatile flammable substances are used or stored, no device generating a spark, or glow flame capable of igniting flammable vapour shall be installed or permitted unless it is enclosed in a flameproof enclosure.
- d) The use, handling, storage and sale of gasoline, fuel oil and other flammable liquids shall not be permitted in Group J occupancies unless such use, handling, storage and sale is in accordance with appropriate legislation in force.
- e) All openings in exterior walls except wall vents shall be protected by a fire stop assembly as in 4 and they shall be fixed, automatic or self-closing. Wall vents having an area of not less than 100 cm² each shall be placed in the exterior walls near the floor line, not more than 1 800 mm apart horizontally. Each building shall be provided with a power driven fan exhaust system of ventilation which shall be arranged and operated so as to produce a complete change of air in each room every 3 min.
- f) Each machine in dry-cleaning establishments which uses flammable liquid shall have an adequate steam line or any other suitable extinguishing agent directly connected to it, so arranged as to have the agent automatically released to the inside of each machine should an explosion occur in the machine.
- g) Equipment or machinery which generates or emits combustible or explosive dust or fibres shall be provided with an adequate dust collecting and exhaust system.

ANNEX A
(Clause 3.1.8)

**CALORIFIC VALUES OF COMMON MATERIALS AND TYPICAL
VALUES OF FIRE LOAD DENSITY**

A-1 The calorific values of some common materials are given in Table 25 for guidance.

Table 25 Calorific Values of Common Materials

Material	Calorific Value (10 ³ kJ/kg ⁻¹) ^D	Wood Equivalent (kg/kg)
(1)	(2)	(3)
Solid Fuels		
Anthracite	28.6	1.66
Bituminous Coal	30.8	1.75
Charcoal	28.4	1.61
Coke (average)	27.5	1.56
Peats	20.9	1.19
Sub-bituminous Coal	22.0	1.25
Woods (hard or softwood)	17.6	1.00
Hydrocarbons		
Benzene	39.6	2.25
Butane	47.1	2.68
Ethane	49.1	2.79
Ethylene	47.7	2.71
Fuel Oil	41.6	2.36
Gas Oil	42.9	2.44
Hexane	44.9	2.55
Methane (natural gas)	52.8	3.00
Octane	45.3	2.58
Paraffin	39.5-44.0	2.3-2.5
Pentane	46.0	2.61
Propane	47.3	2.69
Propylene	46.2	2.63
Alcohols		
Ethyl Alcohol	28.4	1.61
Methyl Alcohol	21.1	1.20
Propyl Alcohol	31.9	1.81
Polymers		
Casein	23.1	1.31
Cellulose	16.5	0.94
Cellulose Acetate	17.8	1.01
Polyethylene	48.4	2.75
Polypropylene	48.4	2.75
Polystyrene	41.8	2.38
Polyvinylchloride	20.9	1.19
Polyethylmethacrylate	24.6	1.40
Polyurethane	35.2	2.00
Polyamide (nylon)	22.0	1.25
Polyester	22.0	1.25
Common Solids		
Asphalt	38.3	2.13
Bitumen	33.4	1.90
Carbon	32.1	1.83
Cotton (Dry)	15.8	0.90
Flax	14.3	0.81
Furs and Skins	18.7	1.06
Hair (animal)	20.9	1.19
Leather	17.6	1.00

Table 25 — Concluded

(1)	(2)	(3)
Ozokerite (wax)	43.3	2.46
Paper (average)	15.4	0.88
Paraffin wax	40.9	2.33
Pitch	33.0	1.88
Rubber	37.4	2.13
Straw	13.2	0.75
Tallow	37.6	2.14
Tan bark	20.9	1.19
Tar (bituminous)	35.2	2.00
Wool (raw)	21.3	1.23
Wool (scoured)	19.6	1.11
Foodstuffs		
Barely	14.1	0.80
Bran	11.0	0.63
Bread	9.0	0.56
Butter	29.3	1.68
Cheese (Cheddar)	18.1	1.03
Cornmeal	14.1	0.80
Flour	14.1	0.80
Margarine	29.5	1.68
Oatmeal	15.8	0.90
Rice	13.9	0.79
Soyabean Flour	16.1	0.91
Sugar	15.4	0.88
Whole Wheat	14.3	0.81
Miscellaneous		
Acetone	29.7	1.69
Acetaldehyde	25.1	1.43
Formaldehyde	17.6	1.00
Hydrogen	134.2	7.63
Magnesium	24.0	1.36

^D 1 kJ is approximately equal to 1 Btu so the figures in the tables are also equivalent to Btu/kg.

A-2 The typical values fire load density for arriving at the classification of occupancy hazard is given in Table 26 for guidance.

Table 26 Typical Values of Fire Load Density

Sl No.	Building Type	Fire Load Density (Expressed as Wood Equivalent kg/m ²)
(1)	(2)	(3)
i)	Residential (A-1 and A-2)	25
ii)	Residential (A-3 to A-5)	25
iii)	Institutional and Educational (B and C)	25
iv)	Assembly (D)	25-50
v)	Business (E)	25-50
vi)	Mercantile (F)	Up to 250
vii)	Industrial (G)	Up to 150
viii)	Storage and Hazardous (H and J)	Up to 500

ANNEX B

(Clauses 3.1.8 and 3.1.11)

BROAD CLASSIFICATION OF INDUSTRIAL AND NON-INDUSTRIAL OCCUPANCIES INTO DIFFERENT DEGREE OF HAZARD

B-1 LOW HAZARD OCCUPANCIES

Abrasive manufacturing premises
Aerated water factories
Agarbatti manufacturing premises
Analytical and/or Q.C. Laboratories
Arecanut slicing and/or Betelnut factories
Asbestos steam packing and lagging manufacturers
Assembly buildings small (D-4 and D-5)
Battery charging and service stations
Battery manufacturing
Breweries
Brickworks
Canning factories
Cardamom factories
Cement factories and/or asbestos or concrete products manufacturing premises
Ceramic factories, crockery, stoneware pipe manufacturing
Clay works
Clock and watch manufacturing
Clubs
Coffee curing, roasting and grinding factories
Condensed milk factories, milk pasturising plants and dairies
Confectionary manufacturing
Dwellings, lodges, dormitories, etc
Educational and research institutions
Electric lamps (incandescent and fluorescent) and T.V. tube manufacturing
Electroplating works
Engineering workshops
Fruits and vegetables dehydrating and drying factories
Fruits products and condiment factories
Glass and glass fibre manufacturing
Godowns and warehouses (non-combustible goods)
Gold thread/gilding factories
Gum and/or glue and gelatine manufacturing
Ice candy and ice-cream and ice factories
Ink (excluding printing ink) factories
Mica products manufacturing

Office premises
Places of worship
Pottery works
Poultry farms
Residential buildings (A-1 to A-4) (except hotels A-5)
Salt crushing factories/refineries stables
Sugar candy manufacturing
Sugar factories and refineries
Tanneries
Umbrella assembling factories
Vermicelli factories
Water treatment/filtration plants and water pump houses
Zinc/copper factories

B-2 MODERATE HAZARD OCCUPANCIES

Airport and other transportation terminal buildings
Aluminium factories
Assembly buildings (D-1 to D-3)
Atta and cereal grinding
Bakeries and biscuit factories
Beedi factories
Bobbin factories
Book-binders, envelopes and paper bag manufacturing
Cable manufacturing
Camphor boiling
Candle works
Carbon paper/typewriter ribbon makers
Card board box manufacturing
Carpenters, wood wool and furniture makers
Carpet and durries factories
Cashewnut factories
Chemical manufacturers (using raw materials having F.P > 23°C)
Cigar and cigarette factories
Coir factories
Cold storage premises
Computer installations
Cork products manufacturing (coir, carpets, rugs and tobacco) (hides and skin presses)
Dry cleaning, dyeing and laundries
Electric sub-stations/distribution stations

Electrical generating stations except under ground powerhouses
 Enamelware factories
 Filler and wax paper manufacturing
 Flour mills
 Garment makers
 Ghee factories (other than vegetable)
 Godowns and warehouses (other than non-combustible goods)
 Grains and seed disintegrating or crushing
 Grease manufacturing
 Hosiery, lace, embroidery and thread
 Hospitals including 'X'-ray and other diagnostic clinics (institutional buildings)
 Incandescent gas mantle manufacturers
 Industrial gas manufacturing (only halogenated hydrocarbons/inert gases)
 Man-made yarn/fibre (except acrylic fibre/yarn)
 Manure and fertilizer works (blending, mixing and granulating only)
 Mercantile occupancies (departmental stores, shopping complex, etc)
 Mineral oil blending and processing
 Museums, archives, record rooms
 Oil and leather cloth factories
 Open storage of flammable liquids (in drums, cans, etc)
 Oxygen plants
 Paper and cardboard mills (except raw material yard)
 Piers, wharves, dockyards
 Plastic goods manufacturing
 Plywood/wood veneering factories
 Printing press premises
 Pulverizing and crushing mills
 Residential apartments, hotels, cafes, restaurants
 Rice mills
 Rope works
 Rubber goods manufacturing
 Rubber tyres and tubes manufacturing
 Shellac factories
 Silk filatures
 Soaps and glycerine factories
 Spray painting
 Starch factories
 Tea factories (including blending packing of tea)
 Telephone exchanges, garages
 Textile mills

Tobacco chewing and pan masala making
 Tobacco re-drying factories
 Woolen mills

B-3 HIGH HAZARD OCCUPANCIES

A)

Aircraft hangers
 Aluminium/magnesium powder plants
 Bitumanized paper/hessian cloth/tar felt manufacturing
 Bulk storage of flammable liquids (tank farm, etc)
 Celluloid goods making
 Chemical manufacturers (where raw materials have a F.P. < 23°C)
 Cigarette filter manufacturing
 Cinema films and T.V. production studios
 Coal, coke and charcoal ball and briquettes making
 Collieries, steel plants
 Cotton seeds cleaning and delinting factories
 Cotton waste factories
 Distilleries
 Duplicating/stencil paper making
 Fire works manufacture
 Foamed plastic and/or converting plants
 Godowns of warehouses (combustible/hazardous goods) (H)
 Grass, hay, fodder and *BHOOSA* (chaff)
 Hazardous occupancy buildings (J)
 Industrial gas manufacturing (except halogenated hydrocarbon gases/inert gases)
 Industrial units (G-3 occupancies)
 Jute mills and jute presses
 Linoleum factories
 Man-made fibres (only acrylic fibre/yarn making)
 Match factories
 Mattress and pillow makings (foam plastics)
 Metal or tin printers (if more than 50 percent is engineering, shift to ordinary hazard)
 Oil mills
 Oil extraction plants
 Oil terminals/depots
 Paints/Varnish factories
 Paper and cardboard mills (only raw material yard)
 Pressing factories
 Printing ink making
 Resin, lamp black and turpentine manufacture
 Saw mills

Surgical cotton manufacturing
Tarpaulin and canvas proofing factories
Turpentine and resin distilleries
Tyre retreading and resolving factories
Underground shopping complexes (F-3)

B)

Ammonia and urea synthesis plants

Explosive factories
LPG bottling plants
Petrochemical plants
Petroleum refineries

NOTE — In case of complexes having segregated plants with varying degrees of hazards, the competent authority having jurisdictions shall be consulted to decide the level of protections to be provided.

ANNEX C

(Clauses 3.4.11.1, 4.18.2, 5.1.8, 5.2.2, 6.1.2, 6.2.3, 6.3.2, 6.4.3, 6.5.2, 6.6.2, 6.7.2, 6.8.2 and 6.9.2)

FIRE PROTECTION REQUIREMENTS FOR HIGH RISE BUILDINGS — 15 m IN HEIGHT OR ABOVE

C-0 GENERAL

In addition to the general provisions given in this Part, the Authority may insist on suitable protection measures (see C-1 to C-11) in a building 15 m in height or above.

C-1 CONSTRUCTION

C-1.1 All materials of constructions in load bearing elements, stairways and corridors and facades shall be non-combustible.

C-1.2 The interior finish materials shall not have a flame spreadability rating exceeding Class 1 (see 3.4.15.2).

C-1.3 The internal walls or staircase shall be of brick or reinforced concrete with a minimum of 2 h fire rating.

C-1.4 The staircase shall be ventilated to the atmosphere at each landing and a vent at the top; the vent openings shall be of 0.5 m² in the external wall and the top. If the staircase cannot be ventilated, because of location or other reasons, a positive pressure 50 Pa shall be maintained inside. The mechanism for pressurizing the staircase shall operate automatically with the fire alarm. The roof of the shaft shall be 1 m above the surrounding roof. Glazing or glass bricks if used in staircase, shall have fire resistance rating of minimum 2 h.

C-1.5 Lifts

General requirements of lifts shall be as follows:

- a) Walls of lift enclosures shall have a fire rating of 2 h; lifts shafts shall have a vent at the top of area not less than 0.2 m².
- b) Lift motor room shall be located preferably

on top of the shaft and separated from the shaft by the floor of the room.

- c) Landing doors in lift enclosures shall have a fire resistance of not less than 1 h.
- d) The number of lifts in one row for a lift bank shall not exceed 4 and the total number of lifts in the bank (of two rows) shall not exceed 8. A wall of 2 h fire rating shall separate individual shafts in a bank.
- e) Lift car door shall have a fire resistance rating of half an hour.
- f) Collapsible gates shall not be permitted for lifts and shall have solid doors with fire resistance of at least 1 h.
- g) If the lift shaft and lobby is in the core of the building, a positive pressure between 25 and 30 Pa shall be maintained in the lobby and a positive pressure of 50 Pa shall be maintained in the lift shaft. The mechanism for pressurization shall act automatically with the fire alarm; it shall be possible to operate this mechanically also.
- h) Exit from the lift lobby, if located in the core of the building, shall be through a self-closing smoke stop door of half an hour fire resistance.
- j) Lifts shall not normally communicate with the basement; if, however, lifts are in communication, the lift lobby of the basements shall be pressurized as in (g), with self-closing door as in (h).
- k) Grounding switch(es), at ground floor level, shall be provided on all the lifts to enable the fire service to ground the lifts.
- m) Telephone or other communication facilities

shall be provided in lift cars for building of 30 m in height and above. Communication system for lifts shall be connected to fire control room for the building.

- n) Suitable arrangements such as providing slope in the floor of lift lobby, shall be made to prevent water used during fire fighting, etc, at any landing from entering the lift shafts.
- p) A sign shall be posted and maintained on every floor at or near the lift indicating that in case of fire, occupants shall use the stairs unless instructed otherwise. The sign shall also contain a plan for each floor showing the locations of the stairways.

Alternate source of power supply shall be provided for all the lifts through a manually operated changeover switch.

- q) **Fire Lifts** — Following details shall apply for a fire lift:

- 1) To enable fire services personnel to reach the upper floors with the minimum delay, one fire lift per 1 200 m² of floor area shall be provided and shall be available for the exclusive use of the firemen in an emergency.
- 2) The lift shall have a floor area of not less than 1.4 m². It shall have loading capacity of not less than 545 kg (8 persons lift) with automatic closing doors of minimum 0.8 m width.
- 3) The electric supply shall be on a separate service from electric supply mains in a building and the cables run in a route safe from fire, that is, within the lift shaft. Lights and fans in the elevators having wooden paneling or sheet steel construction shall be operated on 24 V supply.
- 4) Fire fighting lift should be provided with a ceiling hatch for use in case of emergency, so that when the car gets stuck up, it shall be easily openable.
- 5) In case of failure of normal electric supply, it shall automatically trip over to alternate supply. For apartment houses, this changeover of supply could be done through manually operated changeover switch. Alternatively, the lift shall be so wired that in case of power failure, it comes down at the ground level and comes to stand-still with door open.
- 6) The operation of a fire lift is by a simple toggle or two-button switch situated in a glass-fronted box adjacent to the lift at

the entrance level. When the switch is on, landing call-points will become inoperative and the lift will be on car control only or on a priority control device. When the switch is off, the lift will return to normal working. This lift can be used by the occupants in normal times.

- 7) The words 'Fire Lift' shall be conspicuously displayed in fluorescent paint on the lift landing doors at each floor level.
- 8) The speed of the fire lift shall be such that it can reach the top floor from ground level within 1 min.

C-1.6 Basements

C-1.6.1 Each basement shall be separately ventilated. Vents with cross-sectional area (aggregate) not less than 2.5 percent of the floor area spread evenly round the perimeter of the basement shall be provided in the form of grills, or breakable stallboard lights or pavement lights or by way of shafts. Alternatively, a system of air inlets shall be provided at basement floor level and smoke outlets at basement ceiling level. Inlets and extracts may be terminated at ground level with stallboard or pavement lights as before, but ducts to convey fresh air to the basement floor level have to be laid. Stallboard and pavement lights should be in positions easily accessible to the fire brigade and clearly marked 'SMOKE OUTLET' or 'AIR INLET' with an indication of area served at or near the opening.

C-1.6.2 The staircase of basements shall be of enclosed type having fire resistance of not less than 2 h and shall be situated at the periphery of the basement to be entered at ground level only from the open air and in such positions that smoke from any fire in the basement shall not obstruct any exit serving the ground and upper stores of the building and shall communicate with basement through a lobby provided with fire resisting self closing doors of 1 h resistance. For travel distance *see* 4.5. If the travel distance exceeds as given in Table 21, additional staircases shall be provided at proper places.

C-1.6.3 In multi-storey basements, intake ducts may serve all basement levels, but each basement levels and basement compartment shall have separate smoke outlet duct or ducts. Ducts so provided shall have the same fire resistance rating as the compartment itself. Fire rating may be taken as the required smoke extraction time for smoke extraction ducts.

C-1.6.4 Mechanical extractors for smoke venting system from lower basement levels shall also be provided. The system shall be of such design as to

operate on actuation of heat/smoke sensitive detectors or sprinklers, if installed, and shall have a considerably superior performance compared to the standard units. It shall also have an arrangement to start it manually.

C-1.6.4.1 Mechanical extractors shall have an internal locking arrangement, so that extractors shall continue to operate and supply fans shall stop automatically with the actuation of fire detectors.

C-1.6.4.2 Mechanical extractors shall be designed to permit 30 air changes per hour in case of fire or distress call. However, for normal operation, air changes schedule shall be as given in 3.4.11.5.

C-1.6.4.3 Mechanical extractors shall have an alternative source of supply.

C-1.6.4.4 Ventilating ducts shall be integrated with the structure and made out of brick masonry or reinforced cement concrete as far as possible and when this duct crosses the transformer area or electrical switchboard, fire dampers shall be provided.

C-1.6.5 Use of basements for kitchens working on gas fuel shall not be permitted, unless air conditioned.

The basement shall not be permitted below the ward block of a hospital/nursing home unless it is fully sprinkled.

Building services such as electrical sub-stations, boiler rooms in basements shall comply with the provisions of the *Indian Electricity Act/Rules*.

C-1.6.6 If cut outs are provided from basements to the upper floors or to the atmospheres, all sides cut out openings in the basements shall be protected by sprinkler head at close spacing so as to form a water curtain in the event of a fire.

C-1.7 Openable windows on external walls shall be fitted with such locks that can be opened by a fireman's axe.

C-1.8 All floors shall be compartmented with area not exceeding 750 m² by a separation wall with 2 h fire rating, for floors with sprinklers the area may be increased by 50 percent. In long building, the fire separation walls shall be at distances not exceeding 40 m. For departmental stores, shopping centres and basements, the area may be reduced to 500 m² for compartmentation. Where this is not possible, the spacings of the sprinklers shall be suitably reduced. When reducing the spacing of sprinklers, care should be taken to prevent spray from one sprinkler impeding the performance of an adjacent sprinkler head.

C-1.8.1 It is essential to make provisions for drainage of any such water on all floors to prevent or minimize water damage of the contents. The drain pipes should be provided on the external wall for drainage of water

from all floors. On large area floors several such pipes may be necessary which should be spaced 30 m apart. Care shall be taken to ensure that the construction of the drain pipe does not allow spread of fire/smoke from floor to floor.

C-1.9 Service Ducts/Shafts

- a) Service ducts and shafts shall be enclosed by walls of 2 h and doors of 1 h, fire rating. All such ducts/shafts shall be properly sealed and fire stopped at all floor levels.
- b) A vent opening at the top of the service shaft shall be provided having between one-fourth and one-half of the area of the shaft.

C-1.10 Refuse chutes shall have opening at least 1 m above roof level or venting purpose and they shall have an enclosure wall of non-combustible material with fire resistance of not less than 2 h. They shall not be located within the staircase enclosure or service shafts, or air-conditioning shafts inspection panel and doors shall be tight fitting with 1 h fire resistance; the chutes should be as far away as possible from exits.

C-1.11 Refuge Area

Provisions contained in 4.12.3 shall apply for all buildings except multi-family dwellings, refuge area of not less than 15 m² shall be provided on the external walls.

C-1.12 Electrical services shall conform to the following:

- a) The electric distribution cables/wiring shall be laid in a separate duct. The duct shall be sealed at every floor with non-combustible materials having the same fire resistance as that of the duct. Low and medium voltage wiring running in shaft and in false ceiling shall run in separate conduits;
- b) Water mains, telephone lines, intercom lines, gaspipes or any other service line shall not be laid in the duct for electrical cables; use of bus ducts/solid rising mains instead of cables is preferred;
- c) Separate circuits for fire fighting pumps, lifts, staircases and corridor lighting and blowers for pressurizing system shall be provided directly from the main switch gear panel and these circuits shall be laid in separate conduit pipes, so that fire in one circuit will not affect the others. Such circuits shall be protected at origin by an automatic circuit breaker with its no-volt coil removed. Master switches controlling essential service circuits shall be clearly labelled;

- d) The inspection panel doors and any other opening in the shaft shall be provided with air-tight fire doors having fire resistance of not less than 2 h;
- e) Medium and low voltage wiring running in shafts, and within false ceiling shall run in metal conduit. Any 230 V wiring for lighting or other services, above false ceiling, shall have 660 V grade insulation. The false ceiling, including all fixtures used for its suspension, shall be of non-combustible material and shall provide adequate fire resistance to the ceiling in order to prevent spread of fire across ceiling reference may be made to good practice [4(29)];
- f) An independent and well ventilated service room shall be provided on the ground level or first basement with direct access from outside or from the corridor for the purpose of termination of electric supply from the licensees' service and alternative supply cables. The doors provided for the service room shall have fire resistance of not less than 2 h;
NOTE — If service room is located at the first basement, it should have automatic fire extinguishing system.
- g) If the licensees agree to provide meters on upper floors, the licensees' cables shall be segregated from consumers' cables by providing a partition in the duct. Meter rooms on upper floors shall not open into stair case enclosures and shall be ventilated directly to open air outside; and
- h) Suitable circuit breakers shall be provided at the appropriate points.

C-1.13 Gas supply shall conform to the following:

- a) *Town Gas/L.P. Gas Supply Pipes* — Where gas pipes are run in buildings, the same shall be run in separate shafts exclusively for this purpose and these shall be on external walls, away from the staircases. There shall no interconnection of this shaft with the rest of the floors. LPG distribution pipes shall always be below the false ceiling. The length of these pipes shall be as short as possible. In the case of kitchen cooking range area, apart from providing hood, covering the entire cooking range, the exhaust system should be designed to take care of 30 m³ per minute per m² of hood protected area. It should have grease filters using metallic grill to trap oil vapours escaping into the fume hood.

NOTE — For detailed information on gas pipe installations, reference may be made to Part 9 'Plumbing Services, Section 3 Gas Supply'.

- b) All wiring in fume hoods shall be of fibre glass insulation. Thermal detectors shall be installed into fume hoods of large kitchens for hotels, hospitals, and similar areas located in high rise buildings. Arrangements shall be made for automatic tripping of the exhaust fan in case of fire. If LPG is used, the same shall be shut off. The voltage shall be 24 V or 100 V dc operated with external rectifier. The valve shall be of the hand re-set type and shall be located in an area segregated from cooking ranges. Valves shall be easily accessible. The hood shall have manual facility for steam or carbon dioxide gas injection, depending on duty condition; and
- c) Gas meters shall be housed in a suitably constructed metal cupboard located in a well ventilated space, keeping in view the fact that LPG is heavier than air and town gas is lighter than air.

C-1.14 Illumination of Means of Exit

Staircase and corridor lights shall conform to the following (see 4.16 and 4.17 for additional details):

- a) The staircase and corridor lighting shall be on separate circuits and shall be independently connected so as it could be operated by one switch installation on the ground floor easily accessible to fire fighting staff at any time irrespective of the position of the individual control of the light points, if any. It should be of miniature circuit breaker type of switch so as to avoid replacement of fuse in case of crisis;
- b) Staircase and corridor lighting shall also be connected to alternative supply. The alternative source of supply may be provided by battery continuously trickle charged from the electric mains;
- c) Suitable arrangements shall be made by installing double throw switches to ensure that the lighting installed in the staircase and the corridor does not get connected to two sources of supply simultaneously. Double throw switch shall be installed in the service room for terminating the stand-by supply;
- d) Emergency lights shall be provided in the staircase and corridor; and
- e) All wires and other accessories used for emergency light shall have fire retardant property.

C-1.15 A stand-by electric generator shall be installed to supply power to staircase and corridor lighting circuits, fire lifts, the stand-by fire pump, pressurization

fans and blowers, smoke extraction and damper systems in case of failure of normal electric supply. The generator shall be capable of taking starting current of all the machines and circuits stated above simultaneously. If the stand-by pump is driven by diesel engine, the generator supply need not be connected to the stand-by pump. Where parallel HV/LV supply from a separate sub-station is provided with appropriate transformer for emergency, the provision of generator may be waived in consultation with the Authority.

C-1.16 Transformers shall conform to the following:

- a) A sub-station or a switch-station with oil filled equipment shall not be located in the building. The sub-station structure shall have separate fire resisting walls/surroundings and shall necessarily be located at the periphery of the floor having separate access from fire escape stair case. The outside walls, ceiling, floor, openings including doors and windows to the sub-station area shall be provided with a fire resisting door of 2 h fire rating. Direct access to the transformer room shall be provided, preferably from outside fire escape staircase.
- b) The sub-station area needs to be maintained at negative air pressures and area in sub-station shall not be used as storage/dump areas.
- c) When housed inside the building, the transformer shall be of dry type and shall be cut off from the other portion of premises by walls/doors/cutout having fire resistance rating of 4 h.

C-1.17 Air-conditioning shall conform to the following:

- a) Escape routes like staircases, common corridors, lift lobbies, etc, shall not be used as return air passage.
- b) The ducting shall be constructed of substantial gauge metal in accordance with good practice [4(31)].
- c) Wherever the ducts pass through fire walls or floors, the opening around the ducts shall be sealed with materials having fire resistance rating of the compartment.
- d) Where duct crosses a compartment which is fire rated, the ducts shall be fire rated for same fire rating. Further depending on services passing around the duct work, which may get affected in case of fire temperature rising, the ducts shall be insulated.
- e) As far as possible, metallic ducts shall be used even for the return air instead of space above the false ceiling.
- f) Where plenum is used for return air passage,

ceiling and its fixtures shall be of non-combustible material.

- g) The materials used for insulating the duct system (inside or outside) shall be of non-combustible materials. Glass wool shall not be wrapped or secured by any material of combustible nature.
- h) Area more than 750 m² on individual floor shall be segregated by a fire wall and automatic fire dampers for isolation shall be provided [see (j)].
- j) Air ducts serving main floor areas, corridors, etc, shall not pass through the staircase enclosure.
- k) The air-handling units shall be separate for each floor and air ducts for every floor shall be separated and in no way inter-connected with the ducting of any other floor.
- m) If the air-handling unit serves more than one floor, the recommendations given above shall be complied with in addition to the conditions given below:
 - 1) proper arrangements by way of automatic fire dampers working on smoke detector/ or fusible link for isolating all ducting at every floor from the main riser shall be made.
 - 2) When the automatic fire alarm operates, the respective air-handling units of the air-conditioning system shall automatically be switched off.
- n) The vertical shaft for treated fresh air shall be of masonry construction.
- p) The air filters of the air-handling units shall be of non-combustible materials.
- q) The air-handling unit room shall not be used for storage of any combustible materials.
- r) Inspection panels shall be provided in the main trunking to facilitate the cleaning of ducts of accumulated dust and to obtain access for maintenance of fire dampers.
- s) No combustible material shall be fixed nearer than 150 mm to any duct unless such duct is properly enclosed and protected with non-combustible material (glass wool or spunglass with neoprene facing enclosed and wrapped with aluminium sheeting) at least 3.2 mm thick and which would not readily conduct heat.
- t) *Fire Dampers*
 - 1) These shall be located in conditioned air ducts and return air ducts/passages at the following points:
 - i) At the fire separation wall.

- ii) Where ducts/passages enter the central vertical shaft,
 - iii) Where the ducts pass through floors.
 - iv) At the inlet of supply air duct and the return air duct of each compartment on every floor.
- 2) The dampers shall operate automatically and shall simultaneously switch off the air-handling fans. Manual operation facilities shall also be provided.

NOTE — For blowers, where extraction system and duct accumulators are used, dampers shall be provided.

- 3) Fire/smoke dampers (for smoke extraction shafts) for buildings more than 24 m in height.

For apartment houses	In non-ventilated lobbies/ corridors operated by fusible link/smoke detectors and with manual control.
----------------------	--

For other buildings	On operation of smoke detection system and with manual control.
---------------------	---

- 4) Automatic fire dampers shall be so arranged as to close by gravity in the direction of air movement and to remain tightly closed on operation of a fusible link/smoke detector.

C-1.18 Provisions of boiler and boiler rooms shall conform to Indian Boiler Act. Further, the following additional aspects may be taken into account in the location of boiler room:

- a) The boilers shall not be allowed in sub-basement, but may be allowed in the basements away from the escape routes.
- b) The boilers shall be installed in a fire resisting room of 4 h fire resistance rating, and this room shall be situated on the periphery of the basement. Catch-pits shall be provided at the low level.
- c) Entry to this room shall be provided with a composite door of 2 h fire resistance.
- d) The boiler room shall be provided with fresh air inlets and smoke exhausts directly to the atmosphere.
- e) The furnace oil tank for the boiler, if located in the adjoining room shall be separated by fire resisting wall of 4 h rating. The entrance to this room shall be provided with double composite doors. A curb of suitable height shall be provided at the entrance in order to

prevent the flow of oil into the boiler room in case of tank rupture.

- f) Foam inlets shall be provided on the external walls of the building near the ground level to enable the fire services to use foam in case of fire.

C-2 PROVISION OF FIRST-AID FIRE FIGHTING APPLIANCES

The first-aid fire fighting equipment shall be provided on all floors, including basements, lift rooms, etc, in accordance with good practice [4(21)] in consultation with the Authority.

C-3 FIRE ALARM SYSTEM

C-3.1 All buildings with heights of 15 m or above shall be equipped with manually operated electrical fire alarm (MOEFA) system and automatic fire alarm system in accordance with good practice [4(18)] and [4(19)]. However, apartment buildings between 15 m and 30 m in height may be exempted from the installation of automatic fire alarm system provided the local fire brigade is suitably equipped for dealing with fire in a building of 15 m in height or above and in the opinion of the Authority, such building does not constitute a hazard to the safety of the adjacent property or occupants of the building itself.

C-3.1.1 Manually operated electrical fire alarm system shall be installed in a building with one or more call boxes located at each floor. The call boxes shall conform to good practice [4(18)] and [4(19)].

C-3.1.2 The installation of call boxes in hostels and such other places where these are likely to be misused shall as far as possible be avoided. Location of call boxes in dwelling units shall preferably be inside the building.

C-4 LIGHTNING PROTECTION OF BUILDINGS

The lightning protection for buildings shall be provided as given in Part 8 'Building Services, Section 2 Electrical Installations'.

C-5 FIRE CONTROL ROOM

For all buildings 15 m in height or above and apartment buildings with a height of 30 m and above, there shall be a control room on the entrance floor of the building with communication system (suitable public address system) to all floors and facilities for receiving the message from different floors. Details of all floor plans along with the details of fire fighting equipment and installations shall be maintained in the fire control room. The fire control room shall also have facilities to detect the fire on any floor through indicator boards connection; fire detection and alarm systems on all floors. The fire staff incharge of the fire control room

shall be responsible for the maintenance of the various services and fire fighting equipment and installations in co-ordination with security, electrical and civil staff of the building.

C-6 FIRE OFFICER FOR HOTELS, BUSINESS AND MERCANTILE BUILDINGS WITH HEIGHT MORE THAN 30 m

C-6.1 A qualified Fire Officer with experience of not less than 3 years shall be appointed who will be available on the premises.

C-6.2 The Fire Officer shall:

- a) maintain the fire fighting equipment in good working condition at all times,
- b) prepare fire orders and fire operational plans and get them promulgated,
- c) impart regular training to the occupants of the buildings in the use of fire fighting equipments provided on the premises and keep them informed about the fire emergency evacuation plan,
- d) keep proper liaison with city Fire Brigade, and
- e) ensure that all fire precautionary measures are observed at the times.

NOTE — Competent authority having jurisdiction may insist on compliance of the above rules in case of buildings having very large areas even if the height is less than 30 m.

C-7 HOUSE KEEPING

To eliminate fire hazards, good house keeping, both

inside and outside the building, shall be strictly maintained by the occupants and/or the owner of the building.

C-8 FIRE DRILLS AND FIRE ORDERS

Fire notices/orders shall be prepared to fulfil the requirements of fire fighting and evacuation from the buildings in the event of fire and other emergency. The occupants shall be made thoroughly conversant with their actions in the event of emergency, by displaying fire notices at vantage points and also through regular training. Such notices should be displayed prominently in broad lettering.

For guidelines for fire drills and evacuation procedures for high rise buildings, *see* Annex E.

C-9 COMPARTMENTATION

The building shall be suitably compartmentalized so that fire/smoke remain confined to the area where fire incident has occurred and does not spread to the remaining part of the building.

C-10 HELIPAD

For high rise buildings above 60 m in height, provision for helipad should be made.

C-11 MATERIALS FOR INTERIOR DECORATION/FURNISHING

The use of materials which are combustible in nature and may spread toxic fume/gases should not be used for interior decoration/furnishing, etc.

ANNEX D

(Clauses 6.7.3.3 (a) and 6.7.5)

FIRE PROTECTION CONSIDERATIONS FOR VENTING IN INDUSTRIAL BUILDINGS

D-1 APPLICATION AND SCOPE

D-1.1 The provisions given below are applicable only to single storey industrial buildings (factories and storage buildings) covering large floor areas without sub-dividing/separating walls which are usually designed to meet modern production methods.

D-1.2 The requirements of fire and explosion venting of industrial buildings, as dealt with in this section, fall under two categories:

- a) Smoke and fire venting, and
- b) Explosion relief vents.

D-2 SMOKE AND FIRE VENTING

D-2.1 The basic considerations for formulating the design and other requirements for smoke and fire vents are as given in **D-2.1.1** to **D-2.1.20**.

D-2.1.1 The smoke and hot combustion products from a fire, being lighter than the surrounding air, tend to rise and on reaching the roof or ceiling spread out (mushroom) on all sides and form a layer which floats on top of the cold air beneath. In the absence of vents, this layer becomes progressively deeper until the whole building is filled with hot smoky gases. The time consumed for this to happen may be only a few

minutes, depending on variables like, type of materials on fire, process/storage conditions involved, etc.

D-2.1.2 The hot gases at the roof level moved by convection currents contribute to rapid lateral spread of fire.

D-2.1.3 The provision of properly designed and suitably located vents in adequate number helps the speedy removal of smoke and hot gases, thereby preventing spread of fire, besides reducing risks of explosion of unburnt gases and reducing damage to the contents and structure of the building by heat and smoke. In addition, they facilitate fire fighting operations, and minimize personal hazards to the firemen.

D-2.1.4 The time taken for accumulation of smoke and hot gases within a building on fire being very short, the venting devices installed shall be designed to operate in the early stage of the fire and must be automatic so as to ensure speed and efficiency in their operation.

D-2.1.5 The smoke and fire venting system shall be designed in such a manner as to keep the temperature of the combustion products from the fire as low as possible, preferably below approximately 150°C.

D-2.1.6 Automatic venting systems are complementary to the fire extinguishing systems, and automatic sprinklers, where provided, should operate before the operation of the vents; otherwise, venting may delay sprinkler operation.

D-2.1.7 It is easier to vent a building of smoke than clear it of smoke once it has been filled.

D-2.1.8 Venting is particularly desirable in large area industrial buildings or warehouses, windowless buildings, underground structures or in areas housing hazardous operations. Automatic fire vents shall be provided for all industrial occupancies (including storage buildings) classified as medium hazard or above having floor areas exceeding 750 m², irrespective of whether they are compartmentalized or not.

D-2.1.9 These provisions do not cover other aspects, of ventilation (or lighting) designed for regulation of temperature within a building for personal comfort or meeting process needs.

D-2.1.10 Similarly, fire and smoke venting requirements as given here under are also not applicable to multi-storey buildings, as their requirements are different and more complex.

D-2.1.11 It is difficult to determine precise venting requirements on account of the many variables involved. For instance, the rate of combustion varies appreciably according to the nature, shape, size and

packaging of the combustible materials as well as the size, height and disposition of the stacks of materials.

D-2.1.12 In industrial buildings of floor area less than 750 m² and used as low fire hazard occupancies, conventional ventilators fitted high up near the eaves of the external walls may serve as vents for smoke and hot gases, provided care is taken to ensure that they are kept open at all times or are designed to open automatically in case of fire.

D-2.1.13 Extinction of fires by closing the doors and windows is not likely in the case of industrial buildings because of their large size, where sufficient air to sustain the fire at least in the initial stages can be expected to be present.

D-2.1.14 Of the two types of building ventilation, namely, vertical and horizontal, vertical ventilation is the one commonly adopted in the case of single storey industrial buildings.

D-2.1.15 Since 70 to 80 percent of heat produced in a fire is convective heat, the ventilation system has to be suitably designed to ensure early outflow of the heat and thereby minimize fire spread.

D-2.1.16 Combustible roof linings shall be avoided, as they themselves will contribute to the spread of fire, thereby multiplying the venting problems.

D-2.1.17 A wind blowing across a flat roof or a roof with a pitch under 40° produces a negative pressure, that is, it tends to draw gases out of the building and so aids venting of hot gases. Wind blowing across a roof of pitch greater than 40° will draw gases out on the leeward side, but oppose outward flow on the windward side of the roof.

D-2.1.18 For vents to work at full efficiency, the area of the inlets for cold air entering the compartment must equal at least the total area of the vents. Ideally, the inlets shall be as close to the ground as possible.

D-2.1.19 Where roof vents are installed in a single-storey building any neighbouring buildings, particularly those of more than one storey, will be subject to some degree of exposure hazard either from flying birds or radiation, or both, as a result.

D-2.1.20 If vents are to be installed, the size, design, number and disposition of the vents and the associated roof screens/curtain boards have to be assessed after careful analysis of the various factors stated under **D-2.1.11** above, as well as other related factors like type of building construction, nature and height of roof, process hazards, exposure hazard, etc.

D-2.2 Venting Area

D-2.2.1 The estimated requirements for ventilation are

largely based on the assumed build-up of the fire from the time of initial outbreak to the time of effective fire fighting action by fire brigade.

D-2.2.2 The vent area required to be provided shall be approximately proportional to the perimeter of the fire area, because the entrained air forms the bulk of the vented gases.

D-2.2.3 The effective area shall be the minimum cross-sectional area through which the hot gases must flow out to the atmosphere.

D-2.2.4 No consideration shall be given to the increased air movement obtained by power operated fans, since it must be assumed that in the event of fire, power will be interrupted, or fans damaged by heat.

D-2.2.5 The total vent areas to be provided shall be as per the following ratios of effective area of vent openings to floor area for various occupancy classifications indicated:

- | | |
|--|--------------|
| a) Low heat release content
(Sub-division G-1) | 1:150 |
| b) Moderate heat release content
(Sub-division G-2) | 1:100 |
| c) High heat release content
(Sub-division G-3) | 1:30 to 1:50 |

D-2.3 Types of Vents

D-2.3.1 Venting shall be accomplished by any of the types such as monitors continuous gravity vents, until type vents or sawtooth roof skylights.

D-2.3.2 Where monitor type vents are installed, wired glass or metal panels shall be used only if the sash is arranged to open automatically.

D-2.3.3 The use of plain thin glass for venting shall be avoided on account of its unpredictable behaviour during fire. However, if glass or other suitable plastic sheet materials with early disintegration characteristics are used, they should be designed for automatic operation.

D-2.3.4 Where monitors or unit type vents are used, the panels shall be hinged at the bottom and designed to open automatically. Both sides of the vents shall be designed to vent simultaneously to ensure that their effectiveness at the time of fire is not in any way impeded by wind direction.

D-2.3.5 Where movable shutters are provided for continuous gravity vents, these shall open automatically in the event of fire.

D-2.3.6 Unit type vents shall be of relatively small area, ranging between 1 m² and 9 m², having light weight metal frames and housing with hinged dampers

which shall be designed for both manual and automatic operation.

D-2.3.7 Sawtooth roof skylight shall be considered as satisfactory for venting purposes only when designed for automatic operation.

D-2.3.8 Likewise, exterior wall windows shall not be reckoned as satisfactory means for venting of fire gases and smoke in industrial buildings. However, they may be reckoned as additional means of venting when, they are located close to the eaves and are provided with ordinary glass or movable sash arranged for both manual and automatic operation.

D-2.3.9 Baffles shall not be installed inside vents, as they greatly reduce the effective area for venting.

D-2.4 Vent Operation

D-2.4.1 The vents shall be automatic in operation, unless where specified in these provisions that they shall be designed for both manual and automatic operation.

D-2.4.2 The release mechanism shall be simple for operation and independent of electrical power, since electrical services may be interrupted by fire.

D-2.4.3 The automatic operation of vents shall be achieved by actuation of fusible links or other types of heat and smoke detectors, or by interlocking with operation of sprinkler system or any other automatic fire extinguishing system covering the area. Following their release, the vents shall be designed to open by a system of counterweights and associated equipment utilizing the force of gravity or spring loaded levers.

D-2.4.4 Automatic fire alarm system, where installed, shall be coupled to the automatic vents to ensure simultaneous operation.

D-2.4.5 Automatic sprinklers, where installed, shall operate before the vents open in order to avoid any likely delay in sprinkler operation. However, heat actuated devices used for vent release shall be suitably shielded from sprinkler discharge so that water does not delay their action.

D-2.4.6 Premises where height of roof apex is 10 m or more or where the materials handled or stored have high smoke producing characteristics, in addition to fusible links, the vent release mechanism shall be interlinked to smoke actuated automatic fire detectors to ensure early operation of vents.

D-2.4.7 Non-corrosive materials shall be used for hinges, hatches and other related parts to ensure long fail-safe operation of the vents.

D-2.4.8 In case of any doubts regarding the types of vents required to be installed for any particular

occupancy, authorities having jurisdiction shall be consulted.

D-2.5 Size, Spacing and Disposition of Vents

D-2.5.1 Vents shall be correctly sited to ensure their functional efficiency. Ideally, they shall be sited at the highest point in each area to be covered.

D-2.5.2 They shall, as far as possible, be located immediately above the risk to be protected so as to allow free and speedy removal of smoke and other combustion products in the event of fire.

D-2.5.3 The minimum dimension for an effective vent opening shall be not less than 1.25 m in any direction.

D-2.5.4 The spacing of the individual vents shall be based on the principle that more number of well distributed smaller vents are more effective than less number of badly located larger vents.

D-2.5.5 The maximum spacing between vents for the three occupancy classifications shall be as follows:

- a) *Low heat release content* — 45 m between centres
- b) *Moderate heat release content* — 36 to 37 m between centres
- c) *High heat release content* — 22.5 to 30 m between centres, depending on the severity of fire potential.

D-2.5.6 Vents shall be placed in a sheltered situation where advantage can be taken of the prevailing wind. The design of the vent shall be such as to produce a suction effect. A wind blowing across a flat roof or one with a pitch be 40° produces a negative pressure, that is, it tends to draw gases out of the building and so aids venting of hot gases. Wind blowing across a roof of pitch greater than 40° will draw gases out on the leeward side, but oppose outward flow on the windward side of the roof.

D-2.5.7 Low level inlets, with total area not less than the total area of vents, shall be provided to permit outside air to be drawn in to aid automatic venting. These inlets, which may be in the form of doors, windows or such other openings, shall be designed for manual operation when desired.

D-2.6 Roof Screens or Curtain Boards

D-2.6.1 Industrial buildings with large areas and having no sub-division/separating walls limiting the area of individual compartments to 750 m^2 or less, shall be provided with roof screens or curtain boards.

These screens which extend from the roof downwards at specific intervals not only prevent lateral spread of heat and smoke in the event of fire below, but

substantially assist in early operation of automatic sprinklers and vents.

D-2.6.2 They shall be of sheet metal or any other substantial non-combustible material strong enough to withstand damage by heat or impact.

D-2.6.3 They shall be reasonably gas-tight, although small openings for passage of pipes, conduits, etc, shall be permitted.

D-2.6.4 They shall extend down from the roof/ceiling for a minimum depth of 2.2 m. Around specific hazards, the depth shall be 4 m. Where roof/ceiling height exceeds 15 m they shall extend down to within 3 m of the floor. For pitched sawtoothed roofs, they shall extend down to truss level dividing the roof into compartments.

D-2.6.5 In moderate hazard occupancies, the distance between the screens/curtain boards shall not exceed 75 m and the curtained areas shall be limited to a maximum of $4\,500 \text{ m}^2$.

D-2.6.6 In high hazard occupancies, the distance between screens shall not exceed 30 m and the curtained area shall be limited to 750 m^2 .

D-2.6.7 The curtained roof area shall be so arranged that they effectively aid in the venting of smoke and hot gases through the automatic vents provided in each area.

D-2.6.8 In sprinklered buildings, the screens shall preferably be so located as to coincide with the individual sprinkler system areas.

D-3 EXPLOSION RELIEF VENTS

D-3.1 Industrial premises where combustible dusts can accumulate or where flammable gases, vapours or mists in explosive concentrations may be present are constantly exposed to explosion hazards. Pressures developed by such explosions may be of the order of $7 \times 10^5 \text{ Pa}$ and ordinary buildings will not be able to withstand the shock of such pressures. Hence, such buildings require explosion relief vents for preventing structural damage.

D-3.2 Basic Principle/Considerations

D-3.2.1 Most ordinary building walls will not withstand a sustained internal pressure as great as $6.9 \times 10^3 \text{ Pa}$. Hence, explosion relief vents for buildings must be designed to operate at pressures well below those at which the building walls will fail.

D-3.2.2 There is a rise in pressure during an explosion within an enclosure even with open, unobstructed vents, and any delay in opening the venting devices increases that pressure.

D-3.2.3 Structural damage can be minimized by locating hazardous operations or equipment outside buildings and cut off from other operations by a pressure resisting wall. Such isolated processes or equipment shall be housed in single-storey buildings properly vented and a device provided at the inlet of the collector which will prevent an explosion from blowing back through the duct work and into the building.

D-3.2.4 Where highly hazardous operations cannot be located outside of main buildings they shall be segregated by pressure resisting walls and each such unit shall be ventilated outdoors. External walls may be of heavy construction if equipped with suitable vents or high weight panels which blow out easily.

D-3.2.5 Operations or equipment involving explosion hazards shall not be permitted in basements or areas partially below grade.

D-3.2.6 Fire can be expected to follow an explosion in most occupancies, so that any fixed fire extinguishing equipment, like sprinklers, if installed, shall be such that only the minimum damage is caused to it.

D-3.2.7 For a given material, the finer the particle size of the dust, the more violent is the explosion. Some materials, such as aluminium powder, hydrogen, and acetylene, are difficult to vent effectively due to the rapid rate of pressure rise. Some slow burning materials, such as coal dust in a confined space, may do much damage because of the longer duration of their presence. Some dusts, such as magnesium, titanium and zirconium and several metal hydrides may react with water and ignite in some common inert gases, such as nitrogen and carbon dioxide.

D-3.2.8 The maximum explosion pressure in a vented structure decreases as the size of the vent increases, but is independent of the rupturing pressure of a diaphragm.

D-3.2.9 The most effective vent for the release of explosion pressures is an unobstructed vent opening.

D-3.2.10 Pressure required to rupture diaphragms of the same area and material directly varies with the thickness of the material.

D-3.2.11 The slower the rate of pressure rise, the more easily can the explosion be vented.

D-3.2.12 The degree of venting required is directly proportional to the degree of explosion hazard.

D-3.2.13 Experience has shown that most explosions of dusts, vapours and gases do not involve a large part of the total volume of the enclosure, and frequently occur near the upper or lower limits of the explosive range. Consequently, such explosions are relatively weak compared with the optimum.

D-3.2.14 Rectangular unrestricted vents are as effective as square vents of equal area.

D-3.3 Types of Explosion Relief Vents

D-3.3.1 The explosion relief vents shall be any one or more of the following types, depending on individual requirements as assessed by the Authority. Open or unobstructed vents, louvers, open roof vents, hanger type doors, building doors, windows, roof or wall panels or movable fixed sash.

D-3.3.2 The effect of external wind pressure or suction on these devices shall be taken into consideration while designing and selecting the type of vents, since wind pressures may reach over 2×10^5 Pa in severe wind storms.

D-3.3.3 The type of vent for explosion relief for any occupancy shall be selected with life safety as the primary aim followed by minimum damage to property.

D-3.3.4 Where large hanger type doors or metal curtain doors in side walls are used as vents care shall be taken to ensure that they are kept wide open during operations.

D-3.3.5 Where weather hoods are used to cover roof vents, they shall be as light as possible and lightly attached so as to enable them to be blown off quickly when an explosion occurs.

D-3.3.6 Doors and windows when used as explosion vents shall be installed to swing outwards. Doors shall have friction, spring or magnetic latches that will function automatically to permit the door to open under slight internal pressure.

D-3.3.7 Movable sash shall be of the top or bottom hinged or protected type. These shall be equipped with a latch or friction device to prevent accidental opening due to wind action or intrusion. Such latches or locks shall be well maintained.

D-3.3.8 Fixed sash shall be set in place with very light wall anchorages, or, if right, shall be securely fitted and glazed with plastic panes in plastic putty.

D-3.3.9 Where the process is such that the whole of a building or a room may be desirable to arrange for a lightly constructed wall or roof to collapse and thus avert the worst effects of an explosion.

D-3.4 Design, Size and Disposition of Vents

D-3.4.1 The required area of explosion vents shall ordinarily depend on the expected maximum intensity of an explosion in the occupancy, the strength of the structure, the type of vent closure and other factors.

D-3.4.2 Venting shall be planned in such a manner as

to prevent injury to personnel and damage to exposures. In congested locations, substantial ducts or diverters shall be provided to direct the blast.

D-3.4.3 When ductwork is used, the ducts shall be of sufficient strength to withstand the maximum expected explosion pressure.

D-3.4.4 Where explosions are likely within duct and piping systems, they shall be vented by the use of suitable diaphragms designed to blow out at a predetermined pressure. There shall be no physical connection between ductwork system for more than one collector.

D-3.4.5 In large structures, the position of vents shall be relative to the point of origin of explosion, when it can be determined.

D-3.4.6 Where relatively slow explosions involving coal dust, chlorinated solvents, etc. are involved, light, hinged swinging panels may be preferred to diaphragm type of vents.

D-3.4.7 Obstructions of any kind blocking the vents from the risk covered shall be avoided, particularly where risks of rapid violent explosions are present.

D-3.4.8 Counter weights add to the inertia of the vents and so shall be avoided.

D-3.4.9 Various relieving devices, including devices actuated by detonators, shall start to open at as low a pressure as possible. They shall be of light construction, so that full opening can be quickly attained.

D-3.4.10 Vents shall be of such size and design as to prevent rupture of the protected device or apparatus.

D-3.4.11 Skylights or monitors with movable sash that will open outwards, or fixed sash containing panes of glass or plastic that will blow out readily under pressure from within, can be used to supplement wall vents or windows, provided resistance to their displacement or opening is kept as low as consistent with the requirements for structural strength.

D-3.4.12 Flexible plastic sheets when used for vent closures shall be installed in slotted frames in such a way that pressure from within bulges the sheets and releases them from the holding frame.

D-3.4.13 Fragile sheets made of plastic, when used for vent closures, shall be thin sheets that will crack or rupture under less pressure than single strength glass. For this reason use of transparent or translucent plastic sheets is more advantageous instead of glass in window sash.

D-3.4.14 If closed vents are used they shall be larger in area than unenclosed vents to provide equivalent explosion pressure relief.

D-3.4.15 Small enclosures, such as machines, shall be vented more generously than buildings, because if an explosion occurs in a machine, its entire volume may be involved.

D-3.4.16 Vents for the protection of buildings and equipment shall be installed on the following basis:

D-3.4.16.1 Small enclosures of less than 30 m³, machines and ovens of light construction: 1 000 cm² for each 0.3 m³ to 0.9 m³.

D-3.4.16.2 For small enclosures of more substantial construction having reasonably high bursting strength: 1 000 cm² for each 0.9 m³.

D-3.4.16.3 Fairly large enclosures of 30 to 700 m³, such as bins, silos, rooms, storage tanks, etc: 1 000 cm² for each 0.9 m³ to 1.5 m³. In these cases, attempt shall be made to the extent possible to predict the likely point of origin of the explosion in relation to the vent.

D-3.4.16.4 Large rooms and buildings over 700 m³ containing hazardous equipment comprising a small fraction of the entire volume:

- a) *For heavy reinforced concrete, walls* — 100 cm² for each 2.25 m³.
- b) *For light reinforced concrete, brick or wood construction* — 1 000 cm² for each 1.65 m³ to 2.25 m³.
- c) *For lightweight construction such as prefabricated panels* — 1 000 cm² for each 1.5 m³ to 1.65 m³.

D-3.4.16.5 Large rooms or building over 700 m³ containing hazardous equipment comprising a large part of the entire volume of a room or building shall be vented as generously as possible 1 000 cm² for each 0.3 m³ to 1.05 m³.

D-3.4.16.6 In order to obtain these ratios, the size of the building or room must be limited. For some hazardous materials, such as hydrogen, acetylene, carbon disulphide, etc, these limits are extremely low.

D-3.4.17 Emphasis shall always be placed on segregating hazardous areas by means of firewalls or separating walls to prevent spread of fire.

D-3.4.18 Interior walls of light construction, such as tile, shall be avoided in hazardous locations, since they can cause injuries to personnel in the event of an explosion.

ANNEX E

(Clause C-8)

GUIDELINES FOR FIRE DRILL AND EVACUATION PROCEDURES FOR HIGH RISE BUILDINGS (ABOVE 15 m IN HEIGHT)

E-1 INTRODUCTION

In case of fire in a high rise building, safe evacuation of its occupants may present serious problems unless a plan for orderly and systematic evacuation is prepared in advance and all occupants are well drilled in the operation of such plan. These guidelines are intended to assist them in this task.

E-2 ALARMS

Any person discovering fire, heat or smoke shall immediately report such condition to the fire brigade, unless he has personal knowledge that such a report has been made. No person shall make, issue, post or maintain any regulation or order, written or verbal, that would require any person to take any unnecessary delaying action prior to reporting such condition to the fire brigade.

E-3 DRILLS

E-3.1 Fire drills shall be conducted, in accordance with the Fire Safety Plan, at least once every three months for existing buildings during the first two years. Thereafter, fire drills shall be conducted at least once every six months.

E-3.2 All occupants of the building shall participate in the fire drill. However, occupants of the building, other than building service employees, are not required to leave the floor or use the exits during the drill.

E-3.3 A written record of such drills shall be kept on the premises for a three years period and shall be readily available for fire brigade inspection.

E-4 SIGNS AND PLANS

E-4.1 Signs at Lift Landings

A sign shall be posted and maintained in a conspicuous place on every floor at or near the lift landing in accordance with the requirements, indicating that in case of fire, occupants shall use the stairs unless instructed otherwise. The sign shall contain a diagram showing the location of the stairways except that such diagram may be omitted, provided signs containing such diagram are posted in conspicuous places on the respective floor.

A sign shall read "IN CASE OF FIRE, USE STAIRS UNLESS INSTRUCTED OTHERWISE". The lettering shall be at least 12.5 mm block letters in red and white

background. Such lettering shall be properly spaced to provide good legibility. The sign shall be at least 250 mm x 300 mm, where the diagram is also incorporated in it and 62.5 mm x 250 mm where the diagram is omitted. In the latter case, the diagram sign shall be at least 200 mm x 300 mm. The sign shall be located directly above a call-button and squarely attached to the wall or partition. The top of the sign shall not be above 2 m from the floor level.

E-4.2 Floor Numbering Signs

A sign shall be posted and maintained within each stair enclosure on every floor, indicating the number of the floor, in accordance with the requirements given below.

The numerals shall be of bold type and at least 75 mm high. The numerals and background shall be in contrasting colours. The sign shall be securely attached to the stair side of the door.

E-4.3 Stair and Elevator Identification Signs

Each stairway and each elevator back shall be identified by an alphabetical letter. A sign indicating the letter of identification shall be posted and maintained at each elevator landing and on the side of the stairway door from which egress is to be made, in accordance with the requirements given below:

The lettering on the sign shall be at least 75 mm high, of bold type and of contrasting colour from the background. Such signs shall be securely attached.

E-4.4 Stair Re-entry Signs

A sign shall be posted and maintained on each floor within each stairway and on the occupancy side of the stairway where required, indicating whether re-entry is provided into the building and the floor where such re-entry is provided, in accordance with the requirements given below:

The lettering and numerals of the signs shall be at least 12.5 mm high of bold type. The lettering and background shall be of contrasting colours and the signs shall be securely attached approximately 1.5 m above the floor level.

E-4.5 Fire command station shall be provided with floor plan of the building and other pertinent information relative to the service equipment of the building.

E-5 FIRE SAFETY PLAN

E-5.1 A format for the Fire Safety Plan shall be as given in E-8.

E-5.2 The applicable parts of the approved Fire Safety Plan shall be distributed to all tenants of the building by the building management when the Fire Safety Plan has been approved by the Fire Authority.

E-5.3 The applicable parts of the approved Fire Safety Plan shall then be distributed by the tenants to all their employees and by the building management to all their building employees.

E-5.4 Where the owner of the building is also an occupant of the building, he shall be responsible for the observance of these rules and the Fire Safety Plan in the same manner as a tenant.

E-5.5 In the event there are changes from conditions existing at the time the Fire Safety Plan for the building was approved, and the changes are such so as to require amending the Fire Safety Plan, within 30 days after such changes, an amended Fire Safety Plan shall be submitted to the fire brigade for approval.

E-6 FIRE COMMAND STATION

A Fire Command Station shall be established in the lobby of the building on the entrance floor. Such command station shall be adequately illuminated.

E-7 COMMUNICATIONS AND FIRE ALARM

A means of communication and fire alarm for use during fire emergencies shall be provided and maintained by the owner or person in charge of the building.

E-8 FIRE SAFETY PLAN FORMAT

E-8.1 Building Address

Street and Pin Code Number

Telephone Number

E-8.2 Purpose and Objective

E-8.2.1 Purpose

To establish method of systematic, safe and orderly evacuation of an area or building by its occupants in case of fire or other emergency, in the least possible time, to a safe area by the nearest safe means of egress; also the use of such available fire appliances (including sounding of alarms) as may have been provided for controlling or extinguishing fire and safeguarding of human life.

E-8.2.2 Objective

To provide proper education as a part of continuing employee indoctrination and through a continuing

written programme for all occupants, to ensure prompt reporting of fire, the response of fire alarms as designated, and the immediate initiation of fire safety procedures to safeguard life and contain fire until the arrival of the fire brigade.

E-8.3 Fire Safety Director

- a) Name
- b) Regularly assigned employment — Title
- c) Regularly assigned location
- d) How is he notified when at regular location?
- e) How is he notified when not at regular location?
- f) Normal working hours
- g) Duties of Fire Safety Director (*see E-9.1*)

E-8.4 Deputy Fire Safety Director

- a) Name
- b) Regularly assigned employment — Title
- c) Regularly assigned location
- d) How is he notified when at regular location?
- e) How is he notified when not at regular location?
- f) Normal working hours
- g) Duties of Deputy Fire Safety Director (*see E-9.2*)

E-8.5 Fire Wardens and Deputy Fire Wardens

- a) Are their names on Organization Charts for each floor and/or tenancy?
- b) Submit typical completed Organization Chart for Fire Drill and Evacuation Assignment.
- c) Duties of Fire Wardens and Deputy Fire Wardens (*see E-9.3*).

E-8.6 Building Evacuation Supervisor

- a) Name
- b) Regularly assigned employment — Title
- c) Regularly assigned location
- d) How is he notified when at regular location?
- e) How is he notified when not at regular location?
- f) Normal working hours
- g) Duties of Building Evacuation Supervisor (*see E-9.4*).

E-8.7 Fire Party

- a) Submit a completed Organization Chart for Fire Parties naming person in charge, and his title in the building.
- b) Indicate standards of selection from building employees based on background and availability.

- c) How are they notified?
- d) How are they notified when they are not at their regular locations?
- e) Means of responding
- f) Duties of each member of Fire Party (see E-9.5).

E-8.8 Occupants Instructions

Distribution of instructions to all tenants, tenants' employees and building employees (see E-9.6).

E-8.9 Evacuation Drills

- a) Frequency of drills
- b) How conducted?
- c) Participation: Who participated? How?
- d) Controls and supervision
- e) Recording of details of drills

E-8.10 Fire Command Station

- a) Location
- b) Requirements
 - 1) Adequate illumination
 - 2) Adequate communication to mechanical equipment room and elevator control room on each floor
 - 3) Copy of Fire Safety Plan
 - 4) Copy of Building Information Form
 - 5) Representative floor plans showing location of signs, floor remote station, communications, etc.

E-8.11 Signs

- a) Signs at elevator landings, Floor diagrams
- b) Floor numbering
- c) Stairway identification
- d) Elevator identification
- e) Stair re-entry

E-8.12 Fire Prevention and Fire Protection Programme (see E-9.7).

E-8.13 Building Information Form (see E-9.8).

E-8.14 Representative Floor Plan (see E-9.9).

E-8.15 Fire Safety Plan Prepared by (see E-9.10).

- a) Date when prepared.
- b) Date when revised.

E-9 DUTIES

E-9.1 Fire Safety Director's Duties

E-9.1.1 Be familiar with the written Fire Safety Plan providing for fire drill and evacuation procedure in accordance with orders on the subject.

E-9.1.2 Select qualified building service employees for a Fire Party and organize, train and supervise such Fire Brigade.

E-9.1.3 Be responsible for the availability and state of readiness of the Fire Party.

E-9.1.4 Conduct fire and evacuation drills.

E-9.1.5 Be responsible for the designation and training of a Fire Warden for each floor, and sufficient Deputy Fire Wardens for each tenancy in accordance with orders on the subject.

E-9.1.6 Be responsible for a daily check for the availability of the Fire Wardens, and see that up-to-date organization charts are posted.

NOTE — If the number of Fire Wardens and Deputy Fire Wardens in the building is such that it is impractical to individually contact each one daily, a suggested method to satisfy the requirements is to make provisions for the Fire Warden, or a Deputy Fire Warden in the absence of the Fire Warden, to notify the Fire Safety Director when the Fire Warden or required number of Deputy Fire Wardens are not available. In order to determine the compliance by the Fire Warden and Deputy Fire Wardens, when this method is used, the Fire Safety Director shall make a spot check of several different floors each day.

E-9.1.7 Notify the owner or some other person having charge of the building when any designated individual is neglecting his responsibilities contained in Fire Safety Plan. The owner or the other person in-charge of the building shall bring the matter to the attention of the firm employing the individual. If the firm fails to correct the condition, the Fire Department shall be notified by the owner/person in-charge of the building.

E-9.1.8 In the event of fire, shall report to the Fire Command Station to supervise, provide for and coordinate:

- a) Ensure that the Fire Department has been notified of any fire or fire alarm.
- b) Manning of the Fire Command Station.
- c) Direction of evacuating procedures as provided in the Fire Safety Plan.
- d) Reports on conditions on fire floor for information of Fire Department on their arrival.
- e) Advise the Fire Department Officer in-charge in the operation of the Fire Command Station.

E-9.1.9 Be responsible for the training and activities of the Building Evacuation Supervisor.

E-9.2 Deputy Fire Safety Director's Duties

E-9.2.1 Subordinate to the Fire Safety Director.

E-9.2.2 Perform duties of Fire Safety Director in his absence.

E-9.3 Fire Wardens and Deputy Fire Wardens Duties

The tenant or tenants of each floor shall, upon request of the owner or person in charge of buildings, make responsible and dependable employees available for designation by the Fire Safety Director as Fire Warden and Deputy Fire Wardens.

E-9.3.1 Each floor of a building shall be under the direction of a designated Fire Warden for the evacuation of occupants in the event of fire. He shall be assisted in his duties by the Deputy Fire Wardens. A Deputy Fire warden shall be provided for each tenancy. When the floor area of a tenancy exceeds 700 m² of occupiable space, a Deputy Fire Warden shall be assigned for each 700 m² or part thereof.

E-9.3.2 Each Fire Warden and Deputy Fire Warden shall be familiar with the Fire Safety Plan, the location of exits and the location and operation of any available fire alarm system.

E-9.3.3 In the event of fire, or fire alarm the Fire Warden shall ascertain the location of the fire, and direct evacuation of the floor in accordance with directions received and the following guidelines:

- a) The most critical areas for immediate evacuation are the fire floor and floors immediately above.

Evacuation from the other floors shall be instituted when instructions from the Fire Command Station or conditions indicate such action. Evacuation shall be via uncontaminated stairs. The Fire Warden shall try to avoid stairs being used by the Fire Department. If this is not possible, he shall try to attract the attention of the Fire Department Personnel before such personnel open the door to the fire floor.

- b) Evacuation to two or more levels below the fire floor is generally adequate. He shall keep the Fire Command Station informed regarding his location.
- c) Fire Wardens and their Deputies shall see that all occupants are notified of the fire, and that they proceed immediately to execute the Fire Safety Plan.
- d) The Fire Warden on the fire floor shall, as soon as practicable, notify the Fire Command Station of the particulars.
- e) Fire Wardens on floors above the fire shall, after executing the Fire Safety Plan, notify the Fire Command Station of the means being used for evacuation and any other particulars.
- f) In the event that stairways serving fire floor

and/or floors above are unusable due to contamination or cut off by fire and/or smoke or that several floors above fire involve large numbers of occupants who must be evacuated, consideration may be given to using elevators in accordance with the following:

- 1) If the elevators servicing his floor also service the fire floor, they shall not be used. However, elevators may be used if there is more than one bank of elevators, and he is informed from the Fire Command Station that one bank is unaffected by the fire.
- 2) If elevators do not service the fire floor and their shafts have no openings on the fire floor, they may be used, unless directed otherwise.
- 3) Elevators manned by trained building personnel or firemen may also be used.
- 4) In the absence of a serviceable elevator, the Fire Warden shall select the safest stairway to use for evacuation on the basis of the location of the fire and any information received from the Fire Command Station. The Fire Warden shall check the environment in the stairs prior to entry for evacuation. If it is affected by smoke, alternative stair shall be selected, and the Fire Command Station notified.
- 5) The Fire Warden shall keep the Fire Command Station informed of the means being employed for evacuation by the occupants of his floor.

- g) Ensure that an alarm has been transmitted.

E-9.3.4 Organization Chart for Fire Drill and Evacuation Assignment

A chart designating employees and their assignments shall be prepared and posted in a conspicuous place in each tenancy and on each floor of a tenancy that occupies more than one floor and a copy shall be in the possession of the Fire Safety Director.

E-9.3.5 Keep available an updated listing of all personnel with physical disabilities who cannot use stairs unaided. Make arrangements to have these occupants assisted in moving down the stairs to two or more levels below fire floor. If it is necessary to move such occupants to a still lower level during the fire, move them down the stairs to the uppermost floor served by an uninvolved elevator bank and then remove them the street floor by elevator. Where assistance is required for such evacuation, notify Fire Safety Director.

E-9.3.6 Provide for Fire Warden identification during fire drills and fires, such as using armband, etc.

E-9.3.7 Ensure that all persons on the floor are notified of fire and all are evacuated to safe areas. A search must be conducted in the lavatories to ensure all are out. Personnel assigned as searchers can promptly and efficiently perform this duty.

E-9.3.8 Check availability of applicable personnel on Organization Chart and provide for a substitute when the position on a chart is not covered.

E-9.3.9 After evacuation, perform a head count to ensure that all regular occupants known to have occupied the floor have been evacuated.

E-9.3.10 When alarm is received, the Fire Warden shall remain at a selected position in the vicinity of the communication station on the floor, in order to maintain communication with the Fire Command Station and to receive and give instructions.

E-9.4 Building Evacuation Supervisor's Duties

A building Evacuation Supervisor is required at all times other than normal working or business hours when there are occupants in the building and there is no Fire Safety Director on duty in the building.

E-9.4.1 He should be capable of directing the evacuation of the occupants as provided by the Fire Safety Plan.

E-9.4.2 During fire emergencies, the primary responsibility of the Building Evacuation Supervisor shall be to man the Fire Command Station, and the direction and execution of the evacuation as provided in the Fire Safety Plan. The Building Evacuation Supervisor's training and related activities shall be under the direction of the Fire Safety Director in accordance with these rules, and the Fire Safety Plan. Such activities shall be subject to Fire Department control.

E-9.5 Fire Party Duties

On receipt of an alarm for fire the Fire Party shall:

- a) report to the floor below the fire to assist in evacuation and provide information to the Fire Command Station.
- b) after evacuations of fire floor, endeavour to control spread of fire by closing doors, etc.
- c) attempt to control the fire until arrival of the Fire Department, if the fire is small and conditions do not pose a personal threat.
- d) leave one member on the floor below the fire to direct the Fire Department to the fire location and to inform them of conditions.

e) on arrival of the Fire Department, the Fire Party shall report to the Fire Command Station for additional instructions.

f) have a member designated as runner, who shall know the location of the nearest telephone, and be instructed in its use. Such member shall immediately upon receipt of information that there is a fire or evidence of fire, go to the telephone, transmit an alarm and await the arrival of the Fire Department and direct such department to the fire.

NOTE — A chart designating employees and their assignments shall be prepared.

E-9.6 Occupant's Instructions

- a) The applicable parts of the approved Fire Safety Plan shall be distributed to all tenants of the building by the building management when the Fire Safety Plan has been approved by the Fire Commissioner.
- b) The applicable parts of the approved Fire Safety Plan shall then be distributed by the tenants to all their employees and by the building management to all their building employees.
- c) All occupants of the building shall participate and cooperate in carrying out the provisions of the Fire Safety Plan.

E-9.7 Fire Prevention and Fire Protection Programme

- a) A plan for periodic formal inspections of each floor area, including exit facilities, fire extinguishers and house keeping shall be developed. A copy of such plan be submitted.
- b) Provision shall be made for the monthly testing of communication and alarm systems.

E-9.8 Building Information Form

It shall include the following information:

- a) Building address.....Pin Code.....
- b) Owner or person in-charge of building — Name, Address and Telephone Number.
- c) Fire Safety Director and Deputy Fire Safety Director's Name and Telephone Number.
- d) Certificate of occupancy. Location where posted, or duplicate attached.
- e) Height, area, class of construction.
- f) Number, type and location of fire stairs and/or fire towers.
- g) Number, type and location of horizontal exits or other areas of refuge.
- h) Number, type, location and operation of elevators and escalators.

- j) Interior fire alarms, or alarms to central stations.
- k) Communications systems and/or walkie talkie, telephones, etc.
- m) Standpipe system; size and location of risers, gravity or pressure tank, fire pump, location of siamese connections, name of employee with certificate of qualification and number of certificate.
- n) Sprinkler system; name of employee with Certificate of Fitness and certificate number. Primary and secondary water supply, fire pump and areas protected.
- p) Special extinguishing system, if any, components and operation.
- q) Average number of persons normally employed in building. Daytime and night time.
- r) Average number of handicapped people in building. Location. Daytime and night time.
- s) Number of persons normally visiting the building. Daytime and night time.
- t) Service equipment such as:
 - 1) Electric power, primary, auxiliary;
 - 2) Lighting, normal, emergency, type and location;
 - 3) Heating, type, fuel, location of heating unit;
 - 4) Ventilation — with fixed windows, emergency means of exhausting heat and smoke;
 - 5) Air-Conditioning Systems — Brief description of the system, including ducts and floors serviced;
 - 6) Refuse storage and disposal;
 - 7) Fire fighting equipment and appliances, other than standpipe and sprinkler system; and
 - 8) Other pertinent building equipment.
- u) Alterations and repair operations, if any, and the protective and preventive measures necessary to safeguard such operations with attention to torch operations.
- v) Storage and use of flammable solids, liquids and/or gases.
- w) Special occupancies in the building and the proper protection and maintenance thereof. Places of public assembly, studios, and theatrical occupancies.

E-9.9 Representative Floor Plan

A floor plan, representative of the majority or the floor designs of the entire building, shall be at the Command Post, in the main lobby, under the authority of the Fire

Safety Director. One copy of a representative floor plan shall be submitted to the Fire Department with the Fire Safety plan.

E-9.10 Fire Safety Plan

In planning, evaluate the individual floor layouts, the population of floors, the number and kinds of exits, the zoning of the floor by area and occupants. Determine the movement of traffic by the most expeditious route to an appropriate exit and alternative route for each zone, since under fire conditions one or more exits may not be usable. This format is to be used in the preparation of the Fire Safety Plan. Nothing contained in this Fire Safety Plan format is to be construed as all inclusive. All rules and other requirements are to be fully complied with.

E-9.11 Personal Fire Instruction Card

All the occupants of the building shall be given a Personal Fire Instruction Card giving the details of the floor plan and exit routes along with the instruction to be followed in the event of fire. A typical Personal Fire Instruction Card shall be as follows:

PERSONAL FIRE
INSTRUCTION CARD
SEAL

NAME OF THE ORGANIZATION
ADDRESS OF THE ORGANIZATION

NAME:

DESIGNATION:

FLOOR NO.:

DATE:

FIRE WARDEN

INSTRUCTIONS

FOR YOUR OWN SAFETY YOU SHOULD KNOW

1. Two push button fire alarm boxes are provided per floor. You should read the operating instructions.
2. You should read the operating instructions on the body of the fire extinguishers provided on your floor.
3. The nearest exit from your table.
4. Your assembly point on ground floor (check with your Fire/Deputy Fire Warden).
5. **FOR YOUR OWN PROTECTION YOU SHOULD REPORT TO YOUR FIRE/DEPUTY FIRE WARDEN**

- a) If any exit door/route is obstructed by loose materials, goods, boxes, etc.
- b) If any staircase door, lift lobby door does not close automatically, or does not close completely.
- c) If any push button fire alarm point, or fire extinguisher is obstructed, damaged or apparently out of order.

IF YOU DISCOVER A FIRE

1. Break the glass of the nearest push button fire alarm and push the button.
2. Attack the fire with extinguishers provided on your floor. Take guidance from your Wardens.

3. Evacuate if your Warden asks you to do so.

IF YOU HEAR EVACUATION INSTRUCTIONS

1. Leave the floor immediately by the south/north staircase.
2. Report to your Warden, at your predetermined assembly point outside the building.
3. Do not try to use lifts.
4. Do not go to cloakroom.
5. Do not run or shout.
6. Do not stop to collect personal belongings.
7. Keep the lift lobby and staircase doors shut.

YOUR ASSEMBLY POINT IS

LIST OF STANDARDS

The following list records those standards which are acceptable as 'good practice' and 'accepted standards' in the fulfillment of the requirements of the Code. The standards listed may be used by the Authority as a guide in conformance with the requirements of the referred clauses in the Code.

<i>IS No.</i>	<i>Title</i>	<i>IS No.</i>	<i>Title</i>
(1) 3808 : 1979	Method of test for non-combustibility of building materials (<i>first revision</i>)	3844 : 1989	Code of practice for installation and maintenance of internal fire hydrants and hose reels on premises (<i>first revision</i>)
(2) 8757 : 1999	Glossary of terms associated with fire safety (<i>first revision</i>)	(7) 3614 (Part 1) : 1966	Specification for fire check doors: Part 1 Plate, metal covered and rolling type
7673 : 1975	Glossary of terms for fire fighting equipment	(8) 12458 : 1988	Method of test for fire resistance test for fire stops
(3) 15394 : 2003	Fire safety in petroleum refinery and fertilizer plants — Code of practice	(9) 1646 : 1997	Code of practice for fire safety of buildings (general) : Electrical installations (<i>second revision</i>)
(4) 8758 : 1993	Recommendations for fire precautionary measures in the construction of temporary structures and PANDALS (<i>first revision</i>)	2309 : 1989	Code of practice for protection of building and allied structures against lighting (<i>second revision</i>)
(5) 3809 : 1979	Fire resistance test of structure (<i>first revision</i>)	(10)	Specification for fire dampers for air conditioning ducts (<i>under preparation</i>)
1641 : 1988	Code of practice for fire safety of buildings (general): General principles of fire grading and classification (<i>first revision</i>)	(11) 11360 : 1985	Specification for smoke detectors for use in automatic electrical fire alarm system
15103 : 2002	Specification for fire resistant steel	(12) 659 : 1964	Safety code for air-conditioning
(6) 9668 : 1990	Code of practice for provision and maintenance of water supplies and fire fighting	(13) 1649 : 1962	Code of practice for design and construction of flues and chimneys for domestic heating appliances (<i>first revision</i>)
		1642 : 1989	Code of practice for safety of buildings (general): Details of construction (<i>first revision</i>)
		(14) 12777 : 1989	Fire safety-flame-spread of products — Method for classification

IS No.	Title	IS No.	Title
(15) 1642 : 1989	Code of practice for fire safety of buildings (general): Details of construction (<i>first revision</i>)	906 : 1988	Specification for revolving branch pipe for fire fighting (<i>third revision</i>)
1643 : 1988	Code of practice for fire safety of buildings (general): Exposure hazard (<i>first revision</i>)	907 : 1984	Specification for suction strainers, cylindrical type for fire fighting purpose (<i>second revision</i>)
1644 : 1988	Code of practice for fire safety of buildings (general): Exit requirements and personal hazard (<i>first revision</i>)	908 : 1975	Specification for fire hydrant, stand post type (<i>second revision</i>)
(16) 9457 : 1980	Safety colours and safety signs	909 : 1992	Specification for underground fire hydrant: Sluice valve type (<i>third revision</i>)
12349 : 1988	Fire protection — Safety sign	910 : 1980	Specification for combined key for hydrant, hydrant cover and lower valve (<i>second revision</i>)
12407 : 1988	Graphic symbols for fire protection plan	926 : 1985	Specification for fireman's axe (<i>second revision</i>)
(17) 2175 : 1988	Specification for heat sensitive fire detectors for use in automatic fire alarm system (<i>second revision</i>)	927 : 1981	Specification for fire hooks (<i>second revision</i>)
11360 : 1985	Specification for smoke detectors for use in automatic electrical fire alarm system	928 : 1984	Specification for fire bells (<i>second revision</i>)
(18) 2189 : 1999	Code of practice for selection, installation and maintenance of automatic fire detection and alarm system (<i>second revision</i>)	937 : 1981	Specification for washers for water fittings for fire fighting purposes (<i>second revision</i>)
(19) 636 : 1988	Non-percolating flexible fire fighting delivery hose (<i>third revision</i>)	939 : 1977	Specification for snatch block for use with fibre rope for fire brigade use (<i>first revision</i>)
884 : 1985	Specification for first-aid hose reel for fire fighting (<i>first revision</i>)	940 : 1989	Specification for portable fire extinguisher, water type (gas cartridge) (<i>third revision</i>)
901 : 1988	Specification for couplings, double male and double female instantaneous pattern for fire fighting (<i>third revision</i>)	941 : 1985	Specification for blowers and exhauster for fire fighting (<i>second revision</i>)
902 : 1992	Specification for suction hose couplings for fire fighting purposes (<i>third revision</i>)	942 : 1982	Functional requirements for 275-l/min portable pump set for fire fighting (<i>second revision</i>)
903 : 1993	Specification for fire hose delivery couplings, branch pipe, nozzles and nozzle spanner (<i>fourth revision</i>)	943 : 1979	Functional requirement for 680-l/min trailer pump for fire brigade use (<i>second revision</i>)
904 : 1983	Specification for two-way and three-way suction collecting heads for fire fighting purposes (<i>second revision</i>)	944 : 1979	Functional requirement for 1800-l/min trailer pump for fire brigade use (<i>second revision</i>)
905 : 1980	Specification for delivery breechings, dividing and collecting, instantaneous pattern for fire fighting purposes (<i>second revision</i>)	947 : 1985	Functional requirement for towing tender for trailer fire pump for fire brigade use (<i>first revision</i>)
		948 : 1983	Functional requirement for water tender, Type A, for fire brigade use (<i>second revision</i>)
		949 : 1985	Functional requirement for emergency (rescue) tender for fire brigade use (<i>second revision</i>)

<i>IS No.</i>	<i>Title</i>	<i>IS No.</i>	<i>Title</i>
950 : 1980	Functional requirements for water tender, Type B for fire brigade use (<i>second revision</i>)	4308 : 1982	Specification for dry powder for fire fighting (<i>first revision</i>)
952 : 1986	Specification for foghnozzle for fire brigade use (<i>first revision</i>)	4571 : 1977	Specification for aluminium extension ladders for fire brigade use (<i>first revision</i>)
955 : 1980	Functional requirements for dry power tender for fire-brigade use (150 kg capacity) (<i>first revision</i>)	4643 : 1984	Specification for suction wrenches for fire brigade use (<i>first revision</i>)
957 : 1967	Specification for control van for fire brigade	4861 : 1984	Specification for dry powder for fighting fires in burning metals (<i>first revision</i>)
1941 (Part 1) : 1976	Functional requirements for electric motor sirens: Part 1 ac 3 phase 50Hz, 415 V type (<i>second revision</i>)	4927 : 1992	Specification for unlined flax canvas hose for fire fighting (<i>first revision</i>)
2097 : 1983	Specification for foam making branch pipe (<i>first revision</i>)	4928 : 1986	Specification for delivery valve for centrifugal pump outlets (<i>first revision</i>)
2171 : 1999	Specification for portable fire extinguishers, dry powder (cartridge type) (<i>third revision</i>)	4947 : 1985	Specification for gas cartridges for use in fire extinguishers (<i>second revision</i>)
2175 : 1988	Specification for heat sensitive fire detectors for use in automatic detectors for use in automatic fire alarm system (<i>second revision</i>)	4989 (Part 1) : 2004	Specifications for multipurpose aqueous film forming foam liquid concentrate for extinguishing hydrocarbon and polar solvent fires (<i>third revision</i>)
2298 : 1977	Specification for single-barrel stirrup pump for fire fighting purposes (<i>second revision</i>)	4989 (Part 2) : 1984	Specification for foam concentrate (compound) for producing mechanical foam for fire fighting: Part 2 Aqueous film forming foam (AFFF)
2546 : 1974	Specification for galvanized mild steel fire bucket (<i>first revision</i>)	(Part 3) : 1987	Fluoro protein foam
2696 : 1974	Functional requirements for 1 125 l/min light fire engine (<i>first revision</i>)	5131 : 1986	Specification for dividing breeching with control, for fire brigade use (<i>first revision</i>)
2745 : 1983	Specification for non-metal helmet for firemen and civil defence personnel (<i>second revision</i>)	5290 : 1993	Specification for landing valve (<i>third revision</i>)
2871 : 1983	Specification for branch pipe, universal for fire fighting purposes (<i>first revision</i>)	5486 : 1985	Specification for quick release knife (<i>first revision</i>)
2878 : 2004	Specification for fire extinguisher, carbon-dioxide type (portable and trolley mounted) (<i>third revision</i>)	5505 : 1985	Specification for multi-edged rescue axe (non-wedging) (<i>first revision</i>)
2930 : 1980	Functional requirements for hose laying tender for fire brigade use (<i>first revision</i>)	5612	Specification for hose-clamps and hose-bandages for fire brigade use:
3582 : 1984	Specification for basket strainers for fire fighting purposes (cylindrical type) (<i>first revision</i>)	(Part 1) : 1977	Hose clamps (<i>first revision</i>)
		(Part 2) : 1977	Hose bandages (<i>first revision</i>)
		5714 : 1981	Specification for hydrant, stand-pipe for fire fighting (<i>first revision</i>)

<i>IS No.</i>	<i>Title</i>	<i>IS No.</i>	<i>Title</i>
6026 : 1985	Specification for hand-operated sirens (<i>first revision</i>)	12717 : 1989	Functional requirements of fire fighting equipment — High capacity portable pumpset (1 100-1 600 l/min)
6067 : 1983	Functional requirements for water tender, Type 'X' for fire brigade use (<i>first revision</i>)	12796 : 1989	Specification for fire rake
6234 : 1986	Specification for portable fire extinguishers, water type (stored pressure) (<i>first revision</i>)	13039 : 1991	Code of practice for provision and maintenance of external hydrant system
8090 : 1992	Specification for couplings, branch pipe, nozzle, used in hose reel tubing for fire fighting (<i>first revision</i>)	13385 : 1992	Specification for fire extinguisher 50 capacity wheel mounted water type (gas cartridge)
8096 : 1992	Specification for fire beaters (<i>first revision</i>)	13386 : 1992	Specification for 50 litre capacity fire extinguisher, mechanical foam type
8149 : 1994	Functional requirements for twin CO ₂ fire extinguishers (trolley mounted) (<i>first revision</i>)	13849 : 1993	Specification for portable fire extinguisher dry powder type (constant pressure)
8423 : 1994	Specification for controlled percolating hose for fire fighting (<i>first revision</i>)	14609 : 1999	Specification for ABC dry powder for fire fighting
8442 : 1977	Specification for stand post type water monitor for fire fighting	14933 : 2001	Specification for high pressure fire fighting hose
9972 : 1981	Specification for automatic sprinkler heads	14951 : 2001	Specification for fire extinguisher, 135 litre capacity mechanical foam type
10204 : 1982	Specification for portable fire extinguisher mechanical foam type	15051 : 2002	Specification for high pressure fire hose delivery couplings
10460 : 1983	Functional requirements for small foam tender for fire brigade use	15105 : 2002	Design and installation of fixed automatic sprinkler fire extinguishing system
10658 : 1999	Specification for higher capacity dry powder fire extinguisher (trolley mounted)	15220 : 2002	Specification for halon 1211 and halon 1301 — Fire extinguishing media for fire protection
10993 : 1984	Functional requirements for 2000 kg dry powder tender for fire brigade use	15493 : 2004	Gaseous fire extinguishing systems — General requirements
11070 : 1984	Specification for bromo chlorodifluoromethane (Halon-1211) for fire fighting	15497 : 2004	Specification for gaseous fire extinguishing system — IG 01 extinguishing system
11101 : 1984	Specification for extended branch pipe for fire brigade use	15501 : 2004	Specification for gaseous fire extinguishing system — IG 541 extinguishing system
11108 : 1984	Specification for portable fire extinguisher halon-1211 type	15505 : 2004	Gaseous fire extinguishing systems — HCFC blend A extinguishing systems
11360 : 1985	Specification for smoke detectors for use in automatic electrical fire alarm systems	15506 : 2004	Specification for inert gaseous total fire protection total flooding system — Argonite, IG 55 extinguishing system
11833 : 1986	Specification for dry powder fire extinguisher for metal fires	15517 : 2004	Gaseous fire extinguishing systems — HFC 227 (heptafluoro propane) extinguishing system

IS No.	Title	IS No.	Title
15519 : 2004	Code of practice for water mist fire protection systems — System design, installation and commissioning		ginning and pressing (including cotton seed delinting) factories (<i>first revision</i>)
15525 : 2004	Specification for gaseous fire extinguishing system — IG 100 extinguishing system	3034 : 1993	Code of practice for fire safety of industrial buildings: Electrical generating and distributing stations (<i>second revision</i>)
15528 : 2004	Gaseous fire extinguishing systems — Carbon dioxide, total flooding and local application (sub-flour and in-cabinet), high and low pressure (refrigerated) systems	3058 : 1990	Code of practice for fire safety of industrial buildings: Viscose rayon yarn and/or staple fibre plants (<i>first revision</i>)
(20) 2190 : 1992	Code of practice for selection, installation and maintenance of portable first-aid fire extinguishers (<i>third revision</i>)	3079 : 1990	Code of practice for fire safety of industrial buildings: Cotton textile mills (<i>first revision</i>)
(21) 884 : 1985	Specification for first-aid hose reel for fire fighting (<i>first revision</i>)	3594 : 1991	Code of practice for fire safety of industrial buildings: General storage and warehousing including cold storage (<i>first revision</i>)
15517 : 2004	Code of practice for inspection and maintenance of gaseous fire extinguishing systems	3595 : 1984	Code of practice for fire safety of industrial buildings: Coal pulverizers and associated equipment (<i>first revision</i>)
(22) 3034 : 1993	Code of practice for fire safety of industrial buildings: Electrical generating and distributing stations (<i>second revision</i>)	3836 : 2000	Code of practice for fire safety of industrial buildings: Jute mills (<i>second revision</i>)
(23) 6382 : 1984	Code of practice for design and installation of fixed carbon dioxide fire extinguishing system (<i>first revision</i>)	4209 : 1987	Code of safety in chemical laboratories (<i>first revision</i>)
(24) 14609 : 2001	Specification for dry powder for fire fighting — Class ABC fires	4226 : 1988	Code of practice for fire safety of industrial buildings: Aluminium/Magnesium powder factories (<i>first revision</i>)
15493 : 2004	General requirement for commissioning of gaseous fire extinguishing systems	4886 : 1991	Code of practice for fire safety of industrial buildings: Tea factories (<i>first revision</i>)
(25) 13716 : 1993	Code of practice for fire safety in hotels	6329 : 2000	Code of practice for fire safety of industrial buildings: Saw mills and wood works (<i>first revision</i>)
(26) 4963 : 1987	Recommendations for buildings and facilities for the physically handicapped (<i>first revision</i>)	9109 : 2000	Code of practice for fire safety of industrial buildings: Paint and varnish factories
(27) 4878 : 1986	Bye-laws for construction of cinema buildings (<i>first revision</i>)	11457 (Part 1) : 1985	Code of practice for fire safety of chemical industries: Part 1 Rubber and plastic
(28) 12456 : 1988	Code of practice for fire protection of electronic data processing installations	11460 : 1985	Code of practice for fire safety of libraries and archives buildings
(29) 1646 : 1997	Code of practice for fire safety of buildings (general) : Electrical installations (<i>second revision</i>)	12349 : 1988	Fire protection — Safety signs
2726 : 1988	Code of practice for fire safety of industrial buildings: Cotton	12407 : 1988	Graphic symbols for fire protection plans

<i>IS No.</i>	<i>Title</i>	<i>IS No.</i>	<i>Title</i>
12456 : 1988	Code of practice for fire protection of electronic data processing installation	13694 : 1993	Code of practice for fire safety in iron and steel industries
12458 : 1988	Method of test for fire resistance test of fire stops	13716 : 1993	Code of practice for fire safety of hotels
12459 : 1988	Code of practice for fire-protection of cable runs	14435 : 1997	Code of practice for fire safety in educational institutions
12777 : 1989	Fire safety — Flame spread of products — Method for classification	14689 : 1999	Code of practice for fire safety in printing and publishing industry
13045 : 1991	Code of practice for fire safety in industrial buildings: Floor mills	14850 : 2000	Code of practice for fire safety of museums
		(30) 655 : 1963	Specification for metal air ducts (<i>revised</i>)
		(31) 9583 : 1981	Emergency lighting units